



IEEE

*Advancing Technology
for Humanity*

iee.org



The world's largest technical professional organization for the advancement of technology

Search



- About
- Membership
- Communities
- Conferences**
- Publications
- Standards
- Education

Join

2012 IEEE Symposium on Industrial Electronics and Applications (ISIEA 2012)

IEEE sponsors:

Malaysia Section IE/IA/PEL Joint Chapter

This annual symposium is to bring together scientists, engineers and postgraduates who work in these fields; to share their ideas and experience. Papers are solicited on recent research results, new developments and technology trends in the field of power electronics, industrial electronics, industrial applications, life-science applications, computer & network applications, measurement systems, business applications and ocean applications related technology.

Conference Details

| | |
|---------------------|---|
| Dates | 23 Sep - 26 Sep 2012 |
| Location | Hyatt Regency Bandung, Indonesia |
| Web site | www.isiea.org/2012/ |
| Contact | Mustafar Kamal Hamzah Research Management Institute Universiti Teknologi MARA Shah Alam Selangor DE Malaysia 40450 +60355442091 mustafar@ieee.org +60355442096 (fax) |
| Conference # | 20473 |
| Attendance | 80 |
| Publications | Download conference papers from IEEE Xplore |

Call for Papers for Conference Authors

Find details for paper and abstract submission.
[View call for papers](#)

Abstract submission deadline: 15 Feb 2012
Final submission deadline: 20 Aug 2012
Notification of acceptance date: 01 May 2012

Features

Tutorials

[Back to search results](#)

Please see the [conference Web site](#) for full details.

About IEEE

IEEE is the world's largest technical professional organization dedicated to advancing technology for the benefit of humanity.

- > Learn more about IEEE
- > IEEE Mission & Vision

Membership

- > Join
- > Renew
- > Benefits
- > IEEE Collabratec

Get involved

- > Conferences
- > Local activities
- > Publishing
- > Societies
- > Councils
- > Technical careers
- > Volunteer

Connect with IEEE

Contact & Support

- > IEEE Collabratec
- > Careers at IEEE
- > IEEE Newsroom
- > IEEE Media Kit

Locations

IEEE has a global presence with seven offices internationally.



[↑ top of page](#)

Institutional Sign In

Browse

My Settings

Get Help

Subscribe

Browse Conference Publications > 2012 IEEE Symposium on Industr ...









2012 IEEE Symposium on Industrial Electronics and Applications

23-26 Sept. 2012

Filter Results

Displaying Results 1 - 25 of 83

Show: 25 ▾

| Filter Results | Displaying Results 1 - 25 of 83 | Show: 25 ▾ |
|---|---|------------|
| Search within results: <input type="text"/> <input type="button" value="Search"/> | <input type="checkbox"/> Select All Results | |
| AUTHOR Search for Author <input type="text"/> <ul style="list-style-type: none"> <input type="checkbox"/> Mousa Shamsi (6) <input type="checkbox"/> Mustafar Kamal Hamzah (4) <input type="checkbox"/> Mohd Khairul Mohd Salleh (3) <input type="checkbox"/> Cheng-Ta Chiang (3) <input type="checkbox"/> Mohamad Amin Bakhshali (3) <input type="checkbox"/> Amir Golzarfar (3) <input type="checkbox"/> K. S. Low (2) <input type="checkbox"/> M. Saini (2) <input type="checkbox"/> David Brown (2) <input type="checkbox"/> Hermawan Nugroho (2) <input type="checkbox"/> Zuriati Ahmad Zukarnain (2) <input type="checkbox"/> Hishamuddin Zainuddin (2) <input type="checkbox"/> Mohd Nasir Taib (2) <input type="checkbox"/> M. W. Mustafa (2) <input type="checkbox"/> Montree Kumngern (2) <input type="checkbox"/> Ihsan Mohd Yassin (2) <input type="checkbox"/> Ramli Adnan (2) <input type="checkbox"/> M. Murugappan (2) <input type="checkbox"/> Nooritawati Md Tahir (2) <input type="checkbox"/> Ahmad Fadzil M Hani (2) <input type="checkbox"/> Eduardo E. Zurek (2) <input type="checkbox"/> Luke Axel-Berg (2) <input type="checkbox"/> Suhairi Saharudin (2) <input type="checkbox"/> Mohd Azlan Abu (2) <input type="checkbox"/> Zainudin Kornain (2) | <input type="checkbox"/> [Title page]  Publication Year: 2012, Page(s): 1 <input type="checkbox"/> PDF (24 KB) | |
| | <input type="checkbox"/> Contents  Publication Year: 2012, Page(s): 1 <input type="checkbox"/> PDF (62 KB) | |
| | <input type="checkbox"/> Welcome message  Mustafar Kamal Hamzah ; Nooritawati Md Tahir ; Mohd Khairul Mohd Salleh ; Muhammad Ary Murti ; Zulhabri Ismail Publication Year: 2012, Page(s): 2 <input type="checkbox"/> PDF (58 KB)  HTML | |
| | <input type="checkbox"/> Organizing committee  Publication Year: 2012, Page(s): 3 <input type="checkbox"/> PDF (53 KB) | |
| | <input type="checkbox"/> Reviewers  Publication Year: 2012, Page(s): 4 <input type="checkbox"/> PDF (58 KB) | |
| | <input type="checkbox"/> Technical program overview  Publication Year: 2012, Page(s):5 - 7 <input type="checkbox"/> PDF (68 KB) | |
| | <input type="checkbox"/> Technical program  Publication Year: 2012, Page(s):8 - 14 <input type="checkbox"/> PDF (618 KB) | |
| AFFILIATION Search for Affiliation <input type="text"/> <ul style="list-style-type: none"> <input type="checkbox"/> Department of Electrical Engineering, National Chia Yi University, Taiwan (3) <input type="checkbox"/> Dept. of Electrical Engineering, Sahand University of Technology, Tabriz, Iran (3) <input type="checkbox"/> School of Electrical and Electronic Engineering, Nanyang Technological University, Singapore (2) <input type="checkbox"/> Department of Electrical Engineering, Sahand University | <input type="checkbox"/> Abstract  Publication Year: 2012, Page(s):15 - 28 | |

Proceedings Available

The proceedings of this conference will be available for purchase through Curran Associates.

of Technology, Tabriz, Iran (2)

- Faculty of Electrical Engineering, Universiti Teknologi MARA, Shah Alam, Selangor, Malaysia (2)
- Department of Telecommunications Engineering, Faculty of Engineering, King Mongkut's Institute of Technology Ladkrabang, Bangkok 10520, Thailand (2)
- Department of Electrical and Electronic Engineering, Universidad del Norte, Barranquilla, Colombia (2)
- Faculty of Electrical Engineering, Universiti Teknologi Malaysia, 81310 Skudai, Johor, Malaysia (2)
- School of Computer and Communication Engineering, Universiti Malaysia Perlis, Malaysia (2)
- FSKTM, University Putra Malaysia, Serdang, Malaysia (2)
- Faculty of Electrical Engineering, Universiti Teknologi Malaysia (UTM), Skudai, Johor Baharu, Malaysia (2)
- Faculty of Electrical Engineering, Universiti Teknologi Mara (UiTM), Shah Alam, MALAYSIA (2)
- INSPEM, University Putra Malaysia, Serdang, Malaysia (2)
- MIMOS BERHAD, Technology Park Malaysia, KL, Malaysia (2)
- Central Electron. Eng. Res. Inst., Pilani, India (1)
- University of Portsmouth, UK (1)
- Univ. of Pune, Pune, India (1)
- Faculty of Electrical Engineering, Universiti Teknologi MARA, 40450 Shah Alam, Selangor, Malaysia (1)
- Srinivasa Inst. Of Eng. & Technol., Amalapuram, India (1)
- Sahand University of Technology, Tabriz, Iran (1)
- Department of Systems Engineering, Universidad del Norte, Barranquilla, Colombia (1)
- School of Electrical System Engineering, Universiti Malaysia Perlis, Malaysia (1)
- School of Civil Engineering, Universiti Sains Malaysia (USM), Seri Ampangan, Seberang Perai Selatan, 14300 Nibong Tebal, Pulau Pinang, Malaysia (1)
- Department of Mechatronics Engineering, International Islamic University Malaysia, Kuala Lumpur, Malaysia (1)
- Institute of Materials Engineering, National Pingtung University of Science and Technology, Taiwan (1)

CONFERENCE LOCATION

- Bandung (78)
- Bandung, Indonesia (5)

Previous Titles

2014 IEEE Symposium on Industrial Electronics & Applications (ISIEA)

[Click to expandAbstract](#) | PDF (220 KB)

Author index

Publication Year: 2012, Page(s): 29

[Click to expandAbstract](#) | PDF (30 KB)

A single photon quantum user Bi-directional authentication scheme over noiseless channel

Abudhahir Buhari ; Zuriati Ahmad Zukarnain ; Shamla K. Subramaniam ; Hishamuddin Zainuddin ; Suhairi Saharudin

Publication Year: 2012, Page(s):1 - 6

Cited by: Papers (1)

[Click to expandAbstract](#) | PDF (352 KB) | [HTML](#)

Realization of electronically tunable first-order allpass filter using single-ended OTAs

Montree Kumngern

Publication Year: 2012, Page(s):100 - 103

Cited by: Papers (1)

[Click to expandAbstract](#) | PDF (260 KB) | [HTML](#)

Electronically tunable capacitor-grounded voltage-mode universal filter with four-input one-output using single-ended OTAs

Montree Kumngern

Publication Year: 2012, Page(s):104 - 107

[Click to expandAbstract](#) | PDF (258 KB) | [HTML](#)

Performance evaluation of SRBC circuit using MPPT controller

Nor Zaihar Yahaya ; Ahmad Afifi Afzan Abu Zamir

Publication Year: 2012, Page(s):108 - 113

[Click to expandAbstract](#) | PDF (309 KB) | [HTML](#)

Analysis and simulation of phase-shift control for three-phase AC/DC full-bridge current injection series resonant converter

M. F. Omar ; M. N. Seroji ; M. K. Hamzah

Publication Year: 2012, Page(s):114 - 117

Cited by: Papers (3)

[Click to expandAbstract](#) | PDF (254 KB) | [HTML](#)

A study on performance enhancement of electromagnetic generator via Finite Element Analysis

Zuraini Dahari ; Wong Chin-Chye ; Othman Sidek ; Muhammad Azman Miskam

Publication Year: 2012, Page(s):118 - 123

[Click to expandAbstract](#) | PDF (886 KB) | [HTML](#)

Design of an autonomous remote cellular network service tester

Sharvin Vijayakumar ; Suhanya Jayaprakasam ; Sivajothi Paramasivam ; Quan Zee Teng

Publication Year: 2012, Page(s):12 - 16

[Click to expandAbstract](#) | PDF (909 KB) | [HTML](#)

Industrial Electronics and Applications (ISIEA), 2012 IEEE Symposium on

Print Purchase at Partner

Quick Links

» Search for Upcoming Conferences

» Browse Call for Papers Deadlines

» Organize a Conference









2013 IEEE
Symposium on
Industrial
Electronics &
Applications

2012 IEEE
Symposium on
Industrial
Electronics and
Applications

2011 IEEE
Symposium on
Industrial
Electronics and
Applications

2010 IEEE
Symposium on
Industrial
Electronics and
Applications (ISIEA)

more...

- Effect of shunt capacitance on ferroresonance model for distribution Voltage Transformer** 
- Zulkurnain Abdul Malek ; S. J. Mirazimi ; Kamyar Mehranzamir ; Behnam Salimi
Publication Year: 2012, Page(s):124 - 129
- [©](#) | [Click to expandAbstract](#) | [PDF \(333 KB\)](#) | [HTML](#)
-
- Multiple-Input Single-Output converter for renewable energy sources** 
- Mohammad Taufik ; Taufik Taufik ; Taffy Wong
Publication Year: 2012, Page(s):130 - 135
Cited by: Papers (1)
- [©](#) | [Click to expandAbstract](#) | [PDF \(514 KB\)](#) | [HTML](#)
-
- Ground fault currents in unit generator-transformer at various NGR and transformer configurations** 
- A. R. Sultan ; M. W. Mustafa ; M. Saini
Publication Year: 2012, Page(s):136 - 140
- [©](#) | [Click to expandAbstract](#) | [PDF \(271 KB\)](#) | [HTML](#)
-
- Fault analysis using PSCAD/EMTDC for 150 kV South Sulawesi transmission system** 
- M. Saini ; A. A. Mohd Zin ; M. W. Mustafa ; A. R. Sultan
Publication Year: 2012, Page(s):141 - 146
- [©](#) | [Click to expandAbstract](#) | [PDF \(319 KB\)](#) | [HTML](#)
-
- Transmission loss allocation based on harmonic factor distortion in deregulated electricity supply industry** 
- S. Nojeng ; M. Y. Hassan ; M. P. Abdullah ; F. Hussin
Publication Year: 2012, Page(s):147 - 151
- [©](#) | [Click to expandAbstract](#) | [PDF \(244 KB\)](#) | [HTML](#)
-
- Modeling and simulation of torque hysteresis controller for brushless DC motor drives** 
- Norhazilina Binti Bahari ; Auzani bin Jidin ; Abdul Rahim bin Abdullah ; Md Nazri bin Othman ; Mustafa bin Manap
Publication Year: 2012, Page(s):152 - 155
Cited by: Papers (3)
- [©](#) | [Click to expandAbstract](#) | [PDF \(305 KB\)](#) | [HTML](#)
-
- An approach for fast power restoration plan in a distribution system using ANFIS** 
- Rasli A Ghani ; A. M. Hashim ; Mohd Fauzi Othman
Publication Year: 2012, Page(s):156 - 160
- [©](#) | [Click to expandAbstract](#) | [PDF \(789 KB\)](#) | [HTML](#)
-
- FastICA techniques for load profiles estimation** 
- Mashitah Mohd Hussain ; Zuhaina Hj. Zakaria ; Salleh Serwan
Publication Year: 2012, Page(s):161 - 166
Cited by: Papers (2)
- [©](#) | [Click to expandAbstract](#) | [PDF \(363 KB\)](#) | [HTML](#)
-
- Performance evaluation of R-UPQC and L-UPQC based on a novel voltage detection algorithm** 
- B. S. Mohammed ; K. S. Rama Rao ; R. Ibrahim ; N. Perumal

Ground Fault Currents in Unit Generator-Transformer at Various NGR and Transformer Configurations

A.R. Sultan, M.W. Mustafa, M.Saini
 Faculty of Electrical Engineering
 Universiti Teknologi Malaysia (UTM)
 Skudai, Johor Baharu, Malaysia
 Email : rizal.sultan@fkegraduate.utm.my

Abstract— Single line to ground faults are the most frequent faults likely to occur in the electric power system. The effect of ground fault is determined by generating station arrangements and transformer connections. In this paper, the performance of the generator within the single line to ground fault at various Neutral Grounding Resistors (NGR) and transformer configurations is studied. Simulations were conducted in MATLAB/Simulink and the results are analyzed. A comparison with the impact of faults at various transformer connections is presented. The impact of faults for generator with NGR is also analyzed. On the unit generator-transformer, fault current in the generator neutral is greatest at Yg-Yg transformer connection followed by Yg-Y and Yg- Δ . In addition, for the transformer winding Y-Y, Y-Yg, Y- Δ , Δ -Y, Δ -Yg and Δ - Δ no current flows through the NGR of generator.

Keywords ; ground faults, neutral grounding resistor, transformer configurations

I. INTRODUCTION

In general, the transformer as a step up transformer in electric power station can be categorized as unit generator-transformer configuration, unit generator-transformer configuration with generator breaker, cross-compound generator and generator sharing a unit transformer [1]. Ground fault at transmission line or busbar can have effect on the generator are influenced by system configuration.

Generators are important components of power systems. Knowledge of ground fault at transformer winding connections is essential to choose an appropriate transformer for the given service requirement. Research and applications on transformers have been carried out for decades. IEEE std. C57.12.70- 2000 [2] gives guides and recommended practices for terminal marking and connections for distribution and power transformers. IEEE std. C57.105-1978 [3] provides guides for transformer connections in three-phase distribution systems. IEEE std. 519-1992 [4] and IEEE std. 142-2007 [5] address harmonics and system grounding related to transformers, respectively [6].

The influences of transformer connection on operation are discussed [7] focus on operation included insulation stresses, autotransformer under various condition operations but not included for grounding. A resistance inserted between neutral and ground to limit the value of short-circuit current increases thereby the insulation stresses resulting from line grounds.

The unbalance voltage will reduce if the Yg(weye grounded)-Yg transformer connected to the generator and the Δ (delta)-Yg transformer connected to load [8]. The winding

connection researcher usually recommended for industrial in-plan service is a Δ -Y(weye) at all voltage levels. There are reasoned for various types transformer winding connections to fulfill various needs such as to handle single-phase load, simplify ground relaying, save on initial investment by selecting a proper insulation system, minimize ferroresonance and avoid a harmonic problem[9].

The magnitude of ground fault current, especially at the generator and transformer are determined by generator and transformer winding impedance [1],[10]. The selection and arrangement of protection for generators are influenced to some degree by the method in which the generators are connected to the system and by the overall generating station arrangement. In this paper, the effect of transformer connection which is Y-Y, Y-Yg, Y- Δ , Yg-Y, Yg-Y, Yg- Δ , Δ -Y, Δ -Yg and Δ - Δ transformer to ground fault currents in NGR element for unit generator-transformer configuration, is presented. However, the ferroresonance, harmonic and arcing effects are neglected.

II. PRINCIPLE

A. Ground Faults Currents

The majority of electric faults involve ground. Even faults that are initiated a phase to phase spread quickly to any adjacent metallic housing, conduit, or tray that provides a return path to the system grounding point. Ungrounded systems are also subject to ground faults and require careful attention to ground detection and ground-fault protection. The ground-fault protective sensitivity can be relatively independent of continuous load current values and, therefore, have been lower pick up settings than phase protective devices. The ground-fault currents are not transferred through system power transformers that are connected Δ -Y or Δ - Δ , the ground-fault protection for each system voltage level is independent of the protection at other voltage levels. This configuration permits much faster relaying then can be afforded by phase-protective devices that require coordination using pickup values and time delays extend from the load to the source generators and often result in considerable time delay at some points in the system, Arcing ground faults that are not promptly detected and cleared can be destructive[11].

An ungrounded system has no intentional connection to be ground except through potential indicating or potential-measuring devices or through surge protective devices. While a system is called ungrounded, it is actually coupled to be ground through the distributed capacitance of its phase windings and conductors. A grounded system is intentionally grounded by connecting its neutral

or one conductor to be ground, either solidly or through a current-limiting impedance. Various degrees of grounding are used ranging from solid to high impedance, usually resistance.

Each type of grounding has advantages and disadvantages, and no one method is generally accepted. Factors that influence the choice to include voltage level of power system, transient overvoltage possibilities, type of equipment on the system, required continuity of service, caliber and training of operating and maintenance personnel, methods used on existing systems, availability of convenient grounding point, cost of equipment, safety and tolerable fault damage levels [5].

B. Neutral Grounding Resistors (NGR)

Grounding can be categorized into two general categories: solid grounding and impedance grounding. Impedance grounding may be further divided into several subcategories: reactance grounding, resistance grounding, and ground-fault neutralizer grounding [5]. For generator grounding, the grounding methods dominant are resistance grounding (39,4%), followed by solidly grounding(25,7%) then neutral reactor grounded (17,3 %) [12].

According to IEEE Std 142™-2007 [5], Resistance grounded is grounded through an impedance, the principal element of which is resistance. This grounding method can be divided into High-Resistance Grounded (HRG) and Low-Resistance Grounded (LRG). HRG is a resistance-grounded system designed to limit ground fault current to a value that can be allowed to flow for an extended period of time, while still meeting the criteria of $R0 < Xc0$, so that transient voltages from arcing ground faults are reduced. The ground-fault current is usually limited to less than 10 A, resulting in limited damage even during prolonged faults. Then LRG is a resistance-grounded system that permits a higher ground-fault current to flow to obtain sufficient current for selective relay operation. It usually meets the criteria of $R0/X0$ less than or equal to 2. Ground-fault current is typically between 100 A and 1000 A.

C. Transformer Configuration

The primary and secondary winding can be connected in either wye (Y), delta (Δ) or wye-grounded (Yg) configurations. These result in nine possible combination of connections are Y-Y, Y-Yg, Y- Δ , Yg-Y, Yg-Y, Yg- Δ -, Δ -Y, Δ -Yg and Δ - Δ . The zero-sequence impedance seen looking into a transformer depends upon the configuration of the winding. The zero-sequence impedance of a Δ winding is infinite, whereas the zero-sequence impedance of a Y-connected winding is a series composite of the zero-sequence impedance of the transformer and the impedance of any neutral grounding devices that might be present. Thus, an ungrounded Y-winding would present an infinite zero-sequence impedance because the absence of a neutral grounding connection appears as an open circuit in series with the zero-sequence impedance of the transformer winding itself [11].

The equivalent circuit for the zero-sequence impedances depends on the winding connections and also upon whether or not the neutral is grounded. Figure 1 shows the connection

diagram of some transformer configuration and their zero-sequence equivalent circuits [11].

In Yg-Yg connections, because both neutrals are grounded, there exist a path for zero sequences current to flow in the primary and secondary. In Yg-Y connections, the sum up secondary phase current is zero because the secondary neutral is isolated. For Yg- Δ connections, the primary currents can flow because there is zero-sequence circulating current in the Δ -connected secondary and ground return path for Y-connected primary. In Y- Δ , zero sequences current cannot flow and the equivalent circuits reflect an infinite impedance because the neutral is isolated.

Zero-sequence components of current can flow through a Yg-Yg connected transformer if a neutral path exists on both sides of the transformer. An example is shown in Figure 2. Where a Δ -Yg connected transformer, T1, supplies power to a Yg-Yg connected transformer, T2. A fault on the load side of T2 produces a zero-sequence current, which flows in the primary and secondary windings of that transformer. Zero-sequence current is permitted to flow in the primary of T2 because a path exists in the Δ -Yg connected transformer T1. Disconnecting any of transformer neutrals, on either T1 or T2, would prevent the flow of zero-sequence current in both transformers, except as allowed by magnetizing reactance. Depending upon the connections to the transformer, the use of a Yg-Yg transformer can result in a single system, or its load side may be a separately derived system.

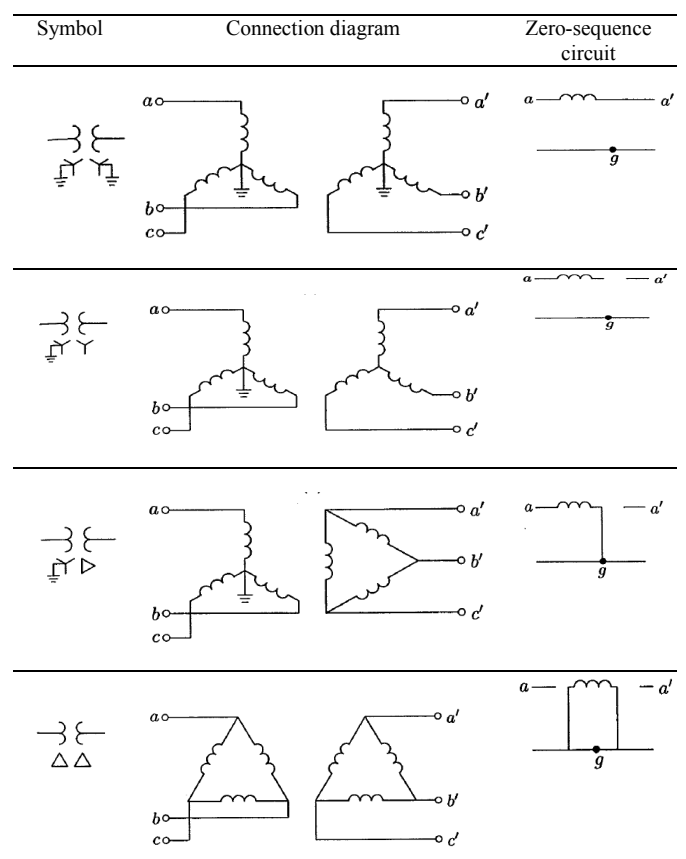

Figure 1. Connection diagram and zero-sequence equivalent circuits [5], [11]

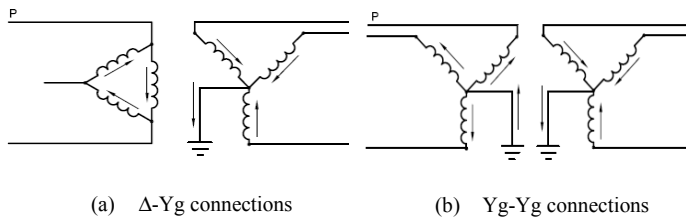

Figure 2. Connection diagram of Δ -Yg and Yg-Yg transformer

III. RESEARCH METHOD

To analyze the performance of various neutral grounding resistor and transformer connections during single line-to-ground fault (SLG), a single-line diagram for the model simulation as illustrated in Figure 3. The following are the system parameters for the testing of the model :

$G1=G2=100$ MVA; 20 kV; $f=60$ Hz; X/R ratio =10

$T1=T2=100$ MVA; 20/220 kV

$L12=L13=L23=220$ kV; line length = 100 km

Extensive simulation tests are carried out. The adjusted parameters are as follows :

- Case 1 : Change the type of transformer connection for fix resistance grounding. The kinds of transformer connection are Y-Y, Y-Yg, Y- Δ , Yg-Y, Yg-Y, Yg- Δ , Δ -Y, Δ -Yg and Δ - Δ transformer. As simulation, The SLG at line 1-2, line 2-3 and line 1-3 and bus 3.
- Case 2 : Change the various of neutral grounding resistor (NGR) element. The values of NGR are 5, 10 ohm , 100 ohm & 500 ohm
- Assume a value of fault resistance when calculating the current for a single line-to-ground fault is 10 ohm. Common values of fault resistance used are 1 to 2, 10, 20, 30, and 40 Ω [13].
- Transition time of ground fault is 1/60 until 6/60 seconds

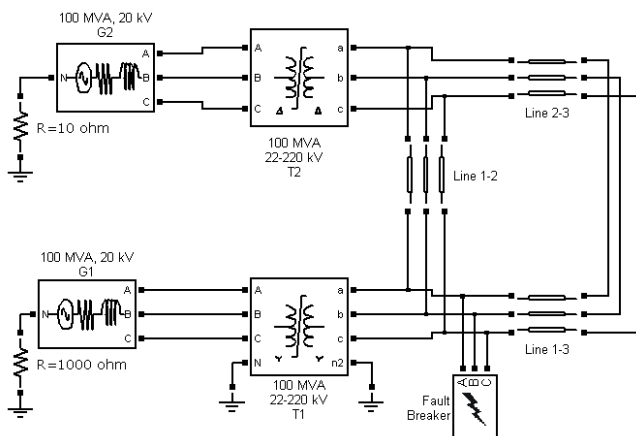

Figure 3. One line diagram for simulation

IV. ANALYSIS OF SIMULATION RESULT

A. Case 1 (various of transformer connections)

The magnitude of ground fault current (GFC) flow through NGR during SLG fault at line 1-3 for various transformer connections shown in Figure 4. The higher of SLG fault can occur at Yg-Yg transformer connection, follow by Yg-Y and Yg- Δ . In Y-Y, Y-Yg, Y- Δ , Δ -Y, Δ -Yg and Δ - Δ transformer connection, there are no current flows in NGR because zero sequences current cannot flow (Y) or no currents can leave the Δ terminals.

The similar condition for SLG fault at line 1-2 and line 2-3, comparison of ground faults current flow through NGR-G1 and NGR-G2 shown in Figure 5. Magnitude GFC at NGR affected by the fault location. This is seen when a ground fault occurs near to the generator 1 (line 1-3), then the effect of ground fault current in the NGR-G1 is greater than the current flowing in the NGR-G2 (Fig.5.a) Similarly, when a ground fault occurs in line 1-2, the NGR-G2 fault current will be greater to the GFC in the NGR-G1. At the time of ground fault occurs at bus 3, then the fault current at NGR-G1 and NGR-G2 will be the same.

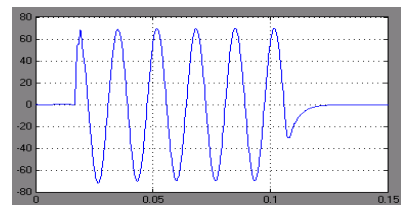

(a) GFC in NGR during SLG at Yg- YgTransformer connection

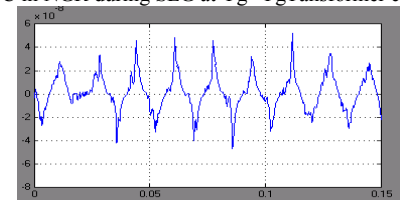

(b) GFC in NGR during SLG at Yg-Y Transformer Connection

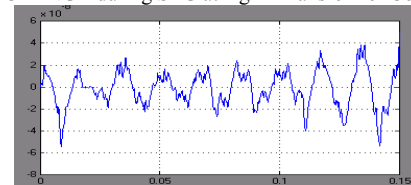

(c) GFC in NGR during SLG at Yg- Δ Transformer Connection

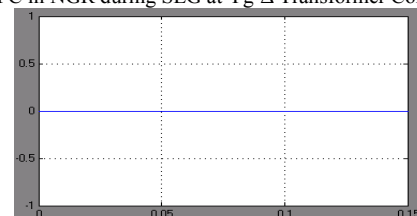

(d) GFC in NGR at Y-Y, Y- Δ , Y-Yg, Δ - Δ , Δ -Yg and Δ -Y

Figure 4. Ground fault current at various transformer connections

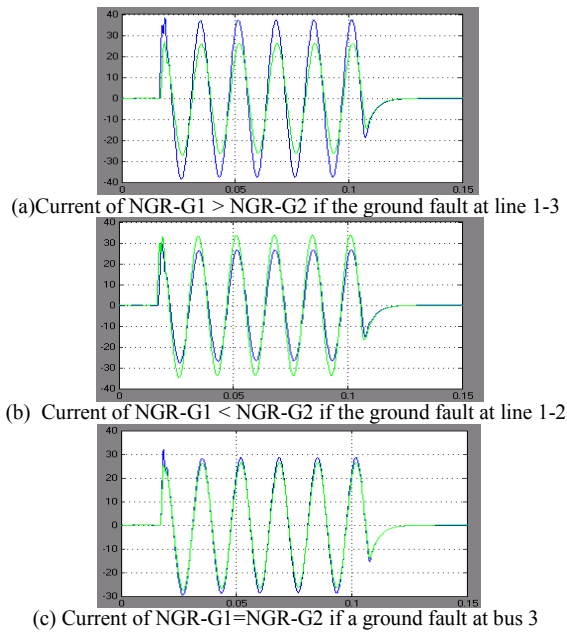

Figure 5. Ground fault current in NGR at varying ground fault locations

Thus the influence of ground fault on the transmission line to ground fault current on the generator grounding is affected by the distance of fault location of the generator and the transformer configuration. The influence of the most significant fault current of the transformer configuration occurs only in Yg-Yg, Yg-Y and Yg- Δ transformer connections.

B. Case 2 (various of NGR values)

Fig.6, shown the grounding with NGR 5 Ω , GFC flowing in the generator neutral approximately 300 A. This value is very large compared the magnitude current flowing the other conditions of NGR. The large the value of NGR, it will cause a current flowing in the NGR will be smaller.

This is a reference because the magnitude of ground fault currents depended on method of neutral grounding. If grounded via low-resistance grounded (LRG), the fault current is great enough to allow the protection tripping, but for the high-resistance grounded (HRG) as the result a very low fault current made the detection of single phase to ground fault very difficult. That ground faults in HRG do not draw enough to trigger circuit breaker or fuse operation. It became one of the considerations the use of the LRG or HRG in ground-fault protection.

Comparison of GFC with different resistance values disorders affecting the characteristic of fault current. Ground fault of the small fault resistance (10 Ω) compared to 40 Ω will result in GFC greater in the NGR element. This is due to the small value of resistance that hinders the ground fault. As same condition for varying magnitude of NGR versus transformer configuration shown at Figure 7.

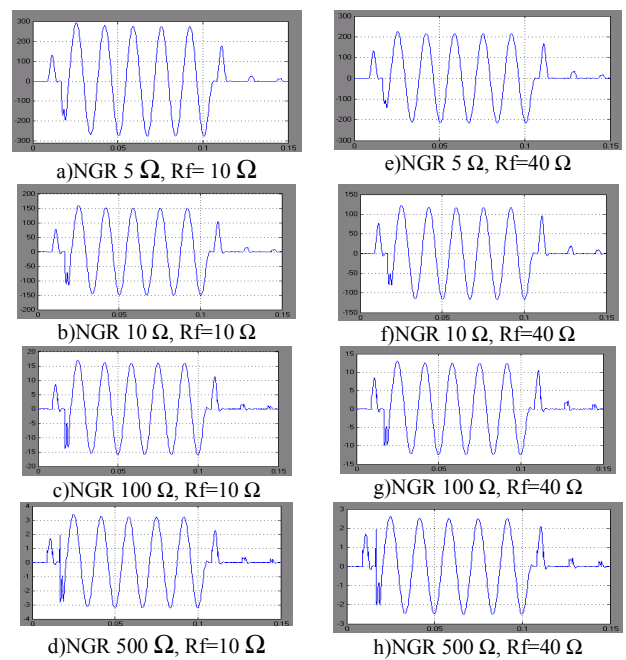

Figure 6. Ground fault current at various value of NGR and fault resistances

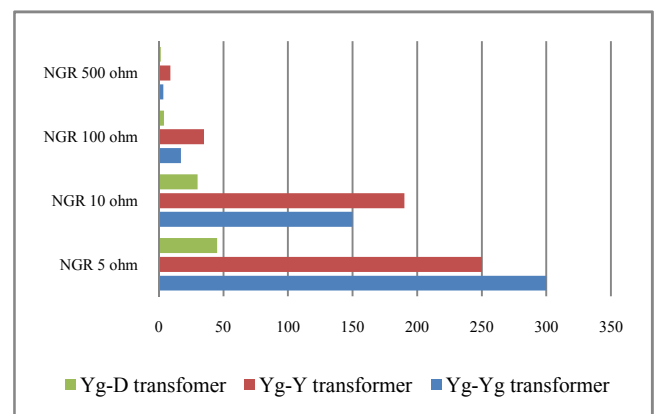

Figure 7. The effect value of NGR versus transformer configuration

V. CONCLUSIONS

Ground fault on the transmission line will affect the current flowing in the NGR element. On the unit generator-transformer, fault current in the generator neutral is greatest at Yg-Yg transformer connection followed by Yg-Y and Yg- Δ . In addition, for the transformer winding Y-Y, Y-Yg, Y- Δ , Δ -Yg and Δ - Δ no current flows through the generator neutral. The magnitude of ground fault currents be affected by the neutral grounding method. If grounded via low-resistance grounded (LRG), the fault current is great, but for the high-resistance grounded (HRG) as a result the very low fault current. According to IEEE Std 142-2007, the ground fault current for HRG limited to less than 10 A and typically between 100 A and 1000A for LRG, it is to the simulation model of NGR 500 ohm including grounding HRG and less

than of NGR 10 ohms can be categorized as LRG. To get a more accurate simulation results, simulation models and the effect of harmonic and ferroresonance can be made for further research.

ACKNOWLEDGMENT

The authors would like to thanks Universiti Teknologi Malaysia, The State Polytechnic of Ujung Pandang and Government of South Sulawesi Indonesia for providing the financial and technical support for research.

REFERENCES

- [1] IEEE Guide for AC Generator Protection, IEEE Std C37.102™-2006
- [2] IEEE Standard for Standard Terminal Markings and Connections for Distribution and Power Transformers, IEEE std. C57.12.70- 2001
- [3] IEEE Guide for Application of Transformer Connections in Three-Phase Distribution Systems, IEEE Std C57.105-1978(R2008)
- [4] IEEE Recommended Practices and Requirements for Harmonic Control in Electric Power Systems, IEEE Std 519-1992 © Institute of Electrical and Electronics Engineers, Inc. 1993.
- [5] IEEE Recommended Practice for Grounding of Industrial and Commercial Power Systems, IEEE Std 142 -2007
- [6] X Liang, W Jackson & R Laughy, Transformer Winding Connections for Industrial Applications, Copyright Material IEEE Paper No. PCIC-2007-19
- [7] Blume,Louis F, "Influence of Transformer Connections on Operation", AIEE, 1914
- [8] Hong, Ying-Yi IEEE Member Wang, Fu-Ming, "Investigation of Impacts of Different Three-phase Transformer Connections and Load Models on Unbalance in Power Systems by Optimization", IEEE Transactions on Power Systems, Vol. 12, No. 2, May 1997
- [9] Walter C. Bloomquist, Fellow IEEE," Select the right Transformer Winding Connection for Industrial Power Systems", IEEE Transactions on Industry Application, VOL. IA-11, NO. 6, November/December 1975
- [10] Fulczyk.M and Bertsch.J, "Ground-Fault Currents in Unit-Connected Generators with different Elements Grounding Neutral", IEEE Transactions on Energy Conversion, Vol. 17, March 2002
- [11] Saadat H." Power System Analysis", McGraw-Hill, 1999
- [12] Short T.A, "Electric Power Distribution Handbook", CRC Press LLC,USA, 2001
- [13] IEEE Recommended Practice for Protection and Coordination of Industrial and Commercial Power Systems, IEEE Std 242-2001, ch.8.