

PAPER • OPEN ACCESS

Modeling of Vertical Dynamic Vibration Characteristics on Vehicles Suspension System

To cite this article: Simon Ka'ka *et al* 2019 *IOP Conf. Ser.: Mater. Sci. Eng.* **619** 012003

View the [article online](#) for updates and enhancements.

You may also like

- [Fuzzy PID control method for damping of electronically controlled air suspension shock absorbers for vehicles](#)
Peng Zhang, WuWei Chen, Hongxin Wang et al.
- [Motion law and density influence of a submersible aerial vehicle in the water-exit process](#)
Qiang Zhang, Jun-hua Hu, Jin-fu Feng et al.
- [Effects of Work on Shock Absorber and Spiral Springs Against Vertical Loads of Vehicles Burdening the Road Structure](#)
S Ka'ka, S Himran, I Renreng et al.



244th Electrochemical Society Meeting

October 8 – 12, 2023 • Gothenburg, Sweden

50 symposia in electrochemistry & solid state science

Abstract submission deadline:
April 7, 2023

Read the call for papers &

submit your abstract!

Modeling of Vertical Dynamic Vibration Characteristics on Vehicles Suspension System

Simon Ka'ka,¹⁾ Syukri Himran,²⁾ Ilyas Renreng,³⁾ Onny Sutresman⁴⁾

¹⁾Mechanical Engineering Department, State Polytechnic of Ujung Pandang, South Sulawesi, Indonesia

^{2,3,4)}Mechanical Engineering Department, Engineering Faculty, Hasanuddin University, South Sulawesi, Indonesia

The corresponding E-mail address: simon_kaka@poliupg.ac.id

Abstract. Vibrations often interfere with driving comfort for riders and passengers. Variations in loads, especially for four-wheeled vehicles, bumps, hollow road surfaces, and other forms of road damage will greatly affect the vehicle suspension work system. This research aims to (1) further test the effect of vertical dynamic load of the vehicle and change the dimension of resistance on the road surface, (2) the contribution of spring and shock absorber to the load fluctuation of the vehicle. Experimentally these load fluctuations are replaced by pneumatic actuator forces of varying magnitude based on the regulatory pressure of the regulator. The deviations generated by the varying load work are measured by placing a proximity sensor along the spring movement. The vertical dynamic load transformation up to the road surface is measured using a "Load cell" mounted under the wheels of the vehicle. Characteristics of vertical dynamic vibration occurring due to several dimensional barriers, U (cm) obtained using mathematical modeling method with 2 DOF suspension system transfer function. The results showed a condition on the body and wheels of vehicles experienced a brief overshoot for 0.14 seconds with deviation of 0.178 m. From the graph shows that the rate of deviation that occurs is large enough that $Y2d = 1.03 \text{ m / s}$ caused by a sudden shock that occurred on the wheels of the vehicle. This condition does not last long that is only duration $t = 0.22 \text{ s}$, because the contribution of springs and shock absorbers that can absorb vibration is 25% to the vibrations caused by the vertical load of the body and the axis of the vehicle.

Keywords; Vibration, suspension, pneumatic actuator, deviation, vertical load.

1 Introduction

The increasing frequency of recurrent vertical loads of four-wheel vehicles passing through the road will decrease the ability of the road to receive the load. Vibrations originating from vertical dynamic loads of vehicles often fluctuate due to unstable drivers and passengers. Such conditions will further weaken the ability of the road structure to accept the fluctuating load. The spring and shock absorber mounted on each of the wheels of the vehicle is expected to be able to overcome and reduce the vertical dynamic load of vehicles overloading the road structure. The vehicle suspension system according to [1-3] is composed of a spring and a shock absorber arranged in parallel. The main function of the suspension system is to support the weight of the vehicle, to provide comfort for the rider, to keep traction of the wheel on the road surface condition, and to maintain the alignment of the front wheel and rear wheel [4-6]. The shape and mechanism of the suspension system is shown in



Fig.1 (a), with sprung mass (m_2), un-sprung mass (m_1), suspension spring (k_2), shock absorbers (c) and tire elastic constants on wheels (k_1), [7-9].

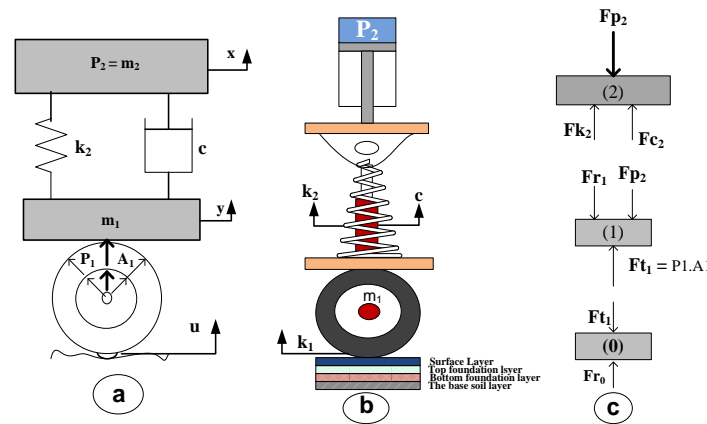

Figure 1 (a) The shape of suspension mechanism, (b) Pneumatic system experimental loading mechanism, (c) Free body diagram

The magnitude of the pneumatic cylinder thrust force generated by the air pressure P_2 (bar) according to [7, 10] is formulated as;

$$F_k = \frac{\pi}{4} D^2 P_2 (N) \tag{1}$$

If the dimensions of the cylinder, $D = 100$ mm (0.100 m) are substituted to equation (1) then the compression force of the suspension mechanism is obtained:

$$F_k = 785 x P_2 \text{ and } F_{p2} = 706.5 P_2 = 707 P_2 (N). \tag{2}$$

Based on the free-body diagram of Figure 1 (c), the equation of the wheel loading the road structure is;

$$\left. \begin{aligned} F_{t1} &= F_{p2} + F_{r1} \\ F_{t1} &= (k_2 + c)x_2 + (m_1 \cdot g) \end{aligned} \right\} (N) \tag{3}$$

If in equation (3), the spring constant k_2 (N / mm), the coefficient of damping c (Ns / mm), the weight of the wheel m_1 (kg) and the gravitational acceleration g (m / s²) are obtained;

$$F_{t1} = F_{r0} = 707 P_2 + (m_1 \cdot g) (N) \tag{4}$$

The mass sprung of m_2 supported by the spring and the shock absorber with the spring stiffness of k_2 and the damping coefficient c will overload the vehicle wheel as the mass unsprung of m_1 further gives the action force to the contour of the road surface. The reaction force of the road contour to the tire will be distributed in the direction of u through the tire elasticity constant of k_1 [9]. Thus the transfer function of a quarter vehicle suspension system for a front wheel with two degrees of freedom (2DOF) is obtained by comparing the output and input as follows:

$$\frac{Y(s)}{U(s)} = \frac{k_1(cs + k_2)}{m_1 m_2 s^4 + (m_1 + m_2)cs^3 + [k_1 m_2 + (m_1 + m_2)k_2]s^2 + k_1 cs + k_1 k_2} \tag{5}$$

Calculation of spring constant value, k_2 by [11, 12] respectively in the book "Machinery's Handbook, 29th Edition and the journal Mechanism and Machine Theory are formulated as follows:

$$k_2 = \frac{Gd^4}{8n_a D^3} \tag{6}$$

G , is the modulus of stiffness (N / cm^2), d is the diameter of the wire (cm), n_a is the number of active coils and D is the mean coil diameter (cm) obtained from the difference between the outer diameter of the coil and the diameter of the wire. The number of active coils, n_a is usually less than the total coil, n whereas the spring compress area is between the minimum compression of 20% and the maximum compression of 80%. If the number of active coils, $n_a = 80\% \times n$, and the mean coil diameter, $D = D_o - d$ then the value of the spring constant, k_2 can be obtained by using equation (6).

2 Research Method

Experimental tests conducted on the mechanical work of suspension on the wheels of the vehicle is by adjusting the working pressure P_2 (bar) on the regulator ranging from 1 to 8 bar [7]. Furthermore, the loading of the spring and the shock absorber by the pneumatic actuator begins to occur when the 5/2 directional control valve is operated. The change in the position of compression motion on the spring and the shock absorber is measured by placing the proximity sensor along the spring movement. The amount of deviation detected by the sensor can be transferred to the LCD in digital form. It should be noted that the change in the size of the readings on the LCD screen is correlated with the regulatory pressure settings. By placing a Load cell gauge just below the wheel of the vehicle, the measurement of the vertical dynamic load of the vehicle successfully transformed to the road surface can be obtained through a direct reading on the LCD screen.

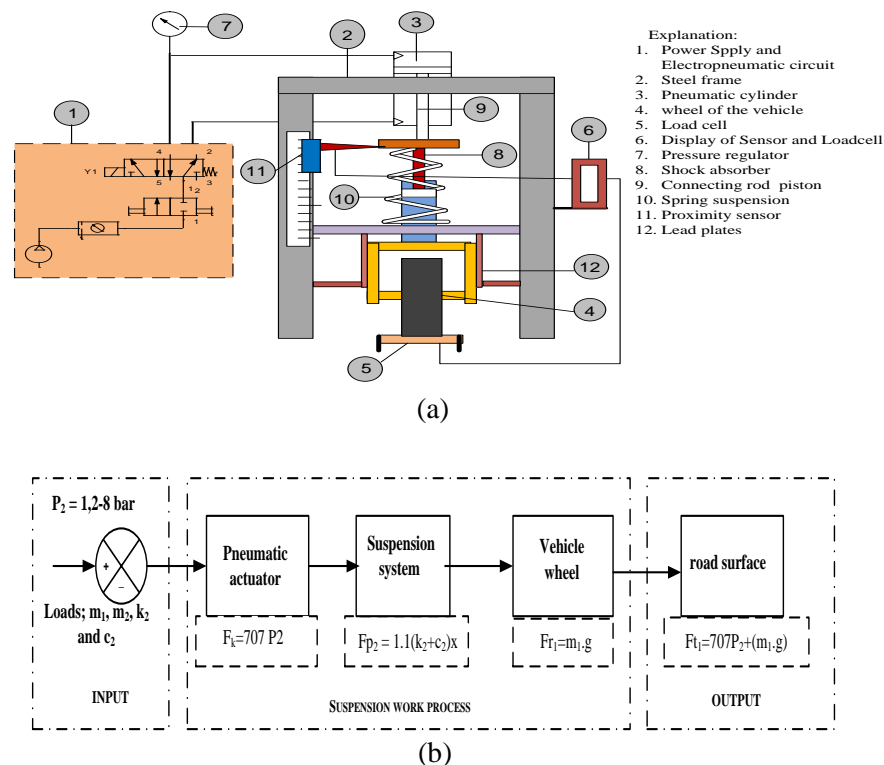

Figure 2 (a) Loading experiments with pneumatic actuators (b) Block diagram of vehicle suspension loading process

Optimization of physical models, using pneumatic cylinders as dynamic vertical drive test simulators on wheel drive suspension work has been discussed by [7].

The type of pneumatic cylinder selected is, DNU-100-300-PVA and sourced from [13] with specifications; Diameter of piston $D = 100$ mm, stroke $L = 300$ mm, Weight piston $W = 3.864$ kg = 38.64 N, and Weight piston rod / 10 mm $w = 0.090$ kg . The forward and reverse thrust force of cylinder piston at a working pressure of 6 bar are respectively $F_k = 4496$ N and $F_m = 4221$ N.

Mathematical model optimization is done by making the weight data of wheel axis, m_1 (kg) and body weight, m_2 (kg) as INPUT as shown in Figure 2 (b). Similarly, the constant values of k_1 , k_2 , and c_2 are the input data to create the program in MatLab.

The test spring used in the suspension system mechanism is a kind of "Helical" with the following specifications: inside and outside coil diameters are $D_i = 12.985$ cm and $D_o = 15.815$ cm, diameter of spring wire, $d = 1.415$ cm, and number of coils, $n = 5$ pieces. The spring material used is from Chrome Vanadium, ASTM A231 with Stiffness Modulus, $G = 7.929E + 10$ Pa = 7.929×10^6 N / cm².

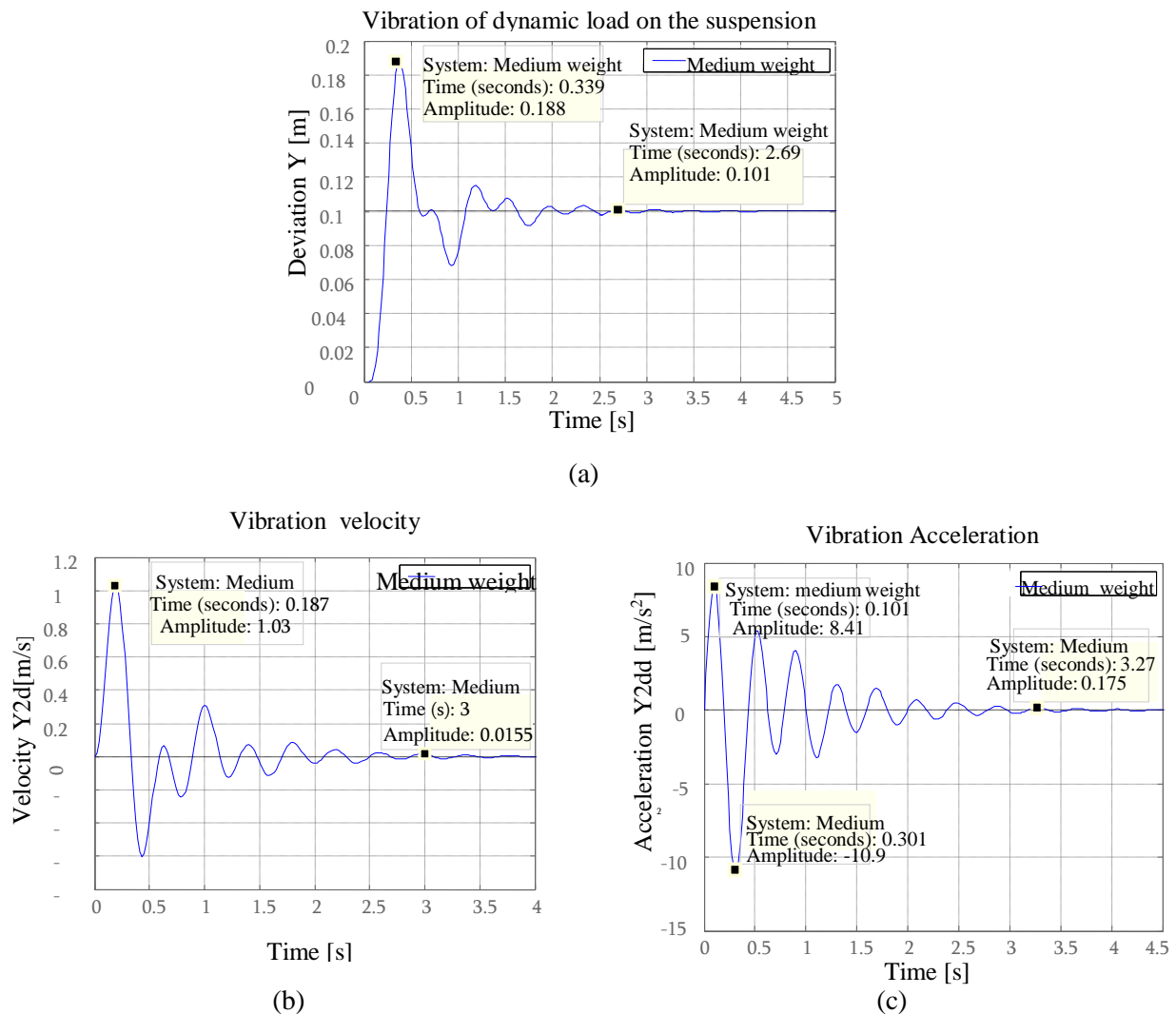

Figure 3 (a) Characteristics of vibration on the body and wheels with deviation Y (m), (b) Characteristics of vibration velocity on the body and wheels, V (m/s), (c) The characteristics of vibration acceleration on the body and wheels, a (m / s^2).

3 Results and Discussion

Programming with Mat Lab software referring to equation (5) will produce the suspension vibration characteristics with small and large deviations as shown in Figure 3(a), (b) and (c). The execution result of the program has obtained the characteristic graph of vibration on the suspension as the impact of vertical dynamic load. In Figure 3(a) if the INPUT resistance is $U = 0.1$ m, then the suspension on the wheels will experience vibration with maximum deviation, $Y = 0.188$ m with a vibration time of 0.339 s. then two seconds later, the minimum deviation occurs at $Y = 0.101$ m.

Proportionally author [14] has obtained 0.12 m deviation on the measured vehicle wheel as a strain using the WIM sensor that placed below the tire.

The characteristic shape of the vibration in the wheel suspension as in Figure 3(a) is caused by a mound as high as $U = 0.1$ (m) on the road surface. Similarly, the reaction to the total dynamic load of the vehicle can result in a vertical overshoot deviation of $Y = 0.188$ (m) with a duration of 0.1 seconds. Furthermore, within a time interval of 2.34 seconds later, the vibrations begin to shrink and stabilize at 0.66 seconds.

Table 1, Characteristics of Experimental Results and Theoretical Deviation

Pressure P_1 (bar)	Experimental		Theoretical	
	t (s)	Y (m)	t (s)	Y (m)
1	0.5	0.059	0.5	0.11
2	1.0	0.067	1	0.087
3	1.6	0.078	1.5	0.11
4	2.1	0.086	2	0.1
5	2.7	0.088	2.5	0.098
6	3.3	0.092	3	0.1
7	3.9	0.096	3.5	0.1
8	4.6	0.098	4	0.099

The result of the research in Figure 3(b) shows that the largest deviation rate $Y2d = 5.51$ m / s occurs at Amplitude, $A = 1.03$ m and the vibration time, $t = 0.187$ s, while the lowest deviation rate is $Y2d = 0.0051$ m / s when the vibration time $t = 3$ s. From the graph shows that the rate of deviation that occurs largely enough caused by a sudden shock that occurs on the wheel. Such conditions can not last long because of the resistance of the spring and shock absorber. The change in the drift velocity shown in Figure 3(c) has a significant slowdown of amplitude, $A = (-10.9 + 8.41)$ m = -2.59 m, at the vibration time, $t = 0.2$ s. The lowest acceleration $Y2dd = 0.014$ m / s² occurs at the vibration time, $t = 0.175$ s.

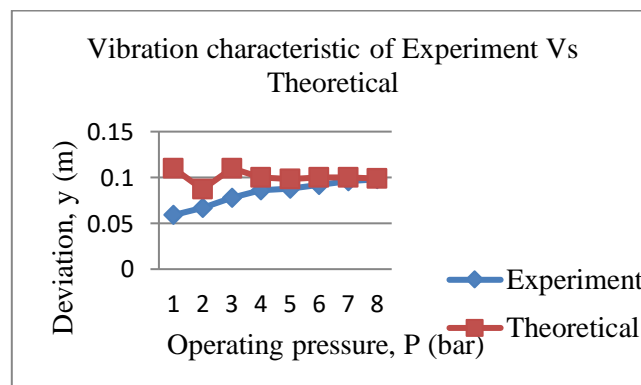

Figure 4. Relationship of vibration characteristics between experimental and theoretical studies.

It should be noted that the perceived comforts of the vehicle are often disrupted by the uneven, hollow, bumpy surface of the road surface and are filled with mound-shaped materials. Comfort can also be felt by passengers and drivers when the mechanism of shock absorber damper is able to reduce vertical dynamic load of the vehicle well.

Given the circulation of liquid or gaseous fluid determined by the regulation of the flow control valve in the cylinder chamber, the performance of the absorbent shock is getting better. The amount of

deviation experienced by the body and the vehicle's axle while experiencing vertical dynamic loads of experimental results and modeling using Mat Lab is shown in Figure 3 above.

The comparison of deviation values between the experimental results and the programming with Mat-Lab is shown in Table 1.

The change in deviation occurring according to the experimental results shows a significant increase with increasing work pressure P_1 (bar) and vibration time t (s). In contrast to the results of deviations obtained through theoretical studies, whereby each increase in vibration time of $t = 0.5$ (s) then the change of deviation Y (m) occurs, does not occur regularly.

The experimental vibration characteristics and theoretical studies show a trend that starting at the working pressure of 4 bars vibration deviation is increasingly blessing each other and finally at the working pressure of 8 bars the deviation is at $Y = 0.1$ m.

The mean deviation of the experimental results is $Y = 0.083$ m, with a mean duration of 2.5 s, while the average deviation of the programming results is $Y = 0.1$ (m) in the mean duration, $t = 4.5$ s.

The rate of deviation and the acceleration of movement of the vehicle body that weighs 300 kg by [4] are 0.03 m and 1.8 m/s^2 respectively and stabilized at $t = 3.5$ (s).

The shape of the deviation graph shows that at the time of vibration, $t = 0.5$ s there is a deviation gap of $Y = 0.051$ m, when pressure $P = 1$ bar, but after reaching the vibration time $t = 2.1$ s when pressure $P = 4$ bar, then the deviation gap starts to decrease to $Y = 0.014$ m.

The magnitude of the vehicle's actual vertical load that overlies the road structure is obtained by multiplying the 80% dynamic factor with the force according to equation (4). If the weight of the vertical load, after getting suspense resistance on the wheels of the vehicle is $Fr_1 = 22197$ (N) then the load of the vehicle that weighs the road is $Ft_1 = 0.8 \times 22197$ (N) = 17758 (N). The magnitude of the reduced vertical load by the spring and the shock absorber is 4439 (N) or equivalent to 25%.

4 Conclusion

Based on the results of experimental studies and analyzes that have been done on the vehicle suspension work performance, it can be concluded as follows:

- 1 Effect of suspension working mechanism on body and wheel of vehicle for medium-weight vehicle type if experiencing disturbance $U = 0,1$ m that happened the biggest deviation $Y = 0,18$ m with duration 0,34 second. In the span of 2.34 seconds later, the vibrations begin to shrink and eventually stabilize at 0.66 seconds. The highest suspension vehicle vibration rate occurs at $Y_{2d} = 5.51 \text{ m / s}$ and the lowest, $Y_{2dd} = 0.0051 \text{ m / s}$ occurs at, $t = 3$ s. At almost the same time, the lowest acceleration is $Y_{2dd} = 0.054 \text{ m / s}^2$. The occurrence of change in deviation speed at the work of the suspension will reduce the driving comfort felt directly by the passengers and drivers.
- 2 The contribution of the spring and the shock absorbers to the fluctuating loads on the vehicle is to reduce the vertical load by 25%.

NOMENCLATURE

Symbol	Unit	Meaning
A, A_0	Cm^2	The area of the tire contact on the road
A_1	m^2	The inside area of the tire
c_2, c	Ns/mm	Coefficient of shock absorber damping
C	-	Coefficient of vehicle distribution
COG	Cm,cm	Center of gravity
D	mm	Piston diameter
D_i	cm,	The inside diameter of the coil
DLC	mm	Dynamic Load Coefficient
D_o	-	The outer diameter of the coil
DOF	cm,	Degree Of Freedom

d	mm	Diameter of spring wire
di	-	Diameter of the air channel
E	-	The vehicle's axis equivalent number
Ee	Pa	Elastic Modulus of the road
F _{Ao}	N	Road stability force
FBD	-	Free Body Diagram
Fc	N	Damping force of shock absorber
F _{Dv}	N	Vertical dynamic vehicle load force
F _{ef}	N	Effective force of piston forward
Fk	N	Theoretical force of piston cylinder
Fp ₂	N	Effective force of piston forward
Fr ₁	N	Force of the wheels
Ft ₁	N	Force of the road surface
Fg	N	Friction force of tires
Fh	N	Horizontal force of tire
fg	-	Coefficient of the road surface
f	1/s	The frequency of vibration
g	m/s ²	Acceleration of gravity
G	Pa	Spring stiffness modulus
k	-	The standard axis correction factor
k ₁ , k _e	N/m	Tire elastic constants
k ₂ , k _s	N/m	The suspension spring constant
Ls	Ton	Axis loads of vehicles
L	cm	The length of the road surface contact area
m ₁	Kg	Unsprung mass of vehicle
m ₂	Kg	Sprung mass of vehicle
n	pieces	The number of spring coils
na	pieces	Number of active coils
P ₁ , p ₁	bar	Air pressure in the tire
P ₂	bar	Working air pressure
t	s	Vibration time
u	mm	Deviation shock absorber
W	N	Total vehicle weight
y	mm	deviation on the suspension spring.

5 References

- [1] M. F.-D. J. Brembeck, "LPV Control of Full-Vehicle Vertical Dynamics using Semi-Active Dampers," *Science Direct*, vol. 49-11, p. 8, 2016.
- [2] M. A. A. Mohd Nizam Sudin¹, Shamsul Anuar Shamsuddin¹, Faiz Redza Ramli¹, Musthafah Mohd Tahir¹, "Review of Research on Vehicles Aerodynamic Drag Reduction Methods," *Review of Research on Vehicles Aerodynamic Drag Reduction Methods*, vol. Vol.14, p. 35, 2014.
- [3] S. W. B. G.R. Chavhan*, Dr.L.P.Dhole, "Analysis Of Shock Absorber Using Different Material Of Spring," *International Journal of Advanced Engineering Technology*, vol. V, pp. 19-21, 2014.

- [4] M. ^a TongyiXu ^a, ChuanLi ^{b,*}, ShuaiYang ^a, "Design and analysis of a shock absorber with variable moment of inertia for passive vehicle suspensions," *Journal of Sound and Vibration*, vol. 355, p. 20, 2015.
- [5] E. A. Finney, "Dynamic Aspect Of Vehicle Size and Weight," p. 23, 2010.
- [6] R. B. Łukasz Konieczny¹, "Modern suspension systems for automotive vehicles and their test methods," *JVE International LTD. Vibroengineering Procedia*, vol. 14, p. 5, 2017.
- [7] Simon Ka'ka¹, Syukri Himran², Ilyas Renreng² and Onny Sutresman², "Pneumatic Actuator As Vertical Dynamic Load Simulator On The Suspension Mechanism Of A Quarter Vehicle Wheels," *ARPN Journal of Engineering and Applied Sciences*, vol. 12, 2017.
- [8] X. J. Y. Z. W. Ma, "Nonlinear dynamic characteristics of a micro-vibration fluid viscous damper," *Springer Science+Business Media, B.V.*, vol. 92, p. 10, 2018.
- [9] V. V. N. I.V. Ryabova, A.V. Pozdeev a,* , "Efficiency of Shock Absorber in Vehicle Suspension," *International Conference on Industrial Engineering, ICIE 2016*, vol. 150, pp. 354 – 362, 2016.
- [10] Simon Ka'ka¹, S.Himran², Ilyas Renreng² and Onny Sutresman², "The Pneumatic Actuators As Vertical Dynamic Load Simulators On Medium Weighted Wheel Suspension Mechanism," *Journal of Physics*, vol. 962, p. 10, 2018.
- [11] E. Edge, "Helical Compression Spring Design Equation and Calculator," *Became An Engineers Edge Contributor*, 2017.
- [12] P.-A. Y. Hassen Trabelsi , * , Jamel Louati, Mohamed Haddar "Interval computation and constraint propagation for the optimal design of a compression spring for a linear vehicle suspension system," *Mechanism and Machine Theory* , journal homepage: www.elsevier.com/locate/mechmt, vol. 48, pp. 67–89, 2015.
- [13] K. Festo, "Automation With Pneumatic," in *Festo Didactic, KG* vol. NR.23099-01/1, ed. Esslingen: Festo Pneumatic, 2015.
- [14] Wenbin Zhang ¹, Chunguang Suo ² and Qi Wang ¹, "A Novel Sensor System for Measuring Wheel Loads of Vehicles on Highways," *Sensors* www.mdpi.com/journal/sensors, vol. 8, p. 19, 2008.

ACKNOWLEDGEMENT

The author would like to thank to Kemenristekdikti, team supervising commission, Mechatronics Study Program of State Polytechnics of Ujung Pandang, and the Department of Mechanical Engineering of Hasanuddin University have much support and facilitate the authors in the form of grants, guidance, and support of laboratory equipment and workshops.