

Sigma Delta ($\Sigma\Delta$) Architecture Integration with Digital Pre-Distortion to Enhance Optimal Switch Mode Power Amplification (OSMPA) in FEMTO Cell Transceiver Design

Sirmayanti Sirmayanti

The State Polytechnic of Ujung Pandang, Indonesia
CTME of Victoria University Melbourne, Australia
sirmayanti.sirmayanti@live.vu.edu.au

Horace King

CTME of Victoria University Melbourne, Australia
horace.king@vu.edu.au

Vandana Bassoo

CTME of Victoria University Melbourne, Australia
vandana.bassoo@live.vu.edu.au

Mike Faulkner

CTME of Victoria University Melbourne, Australia
mike.faulkner@vu.edu.au

Abstract— The work presented in this paper aims to develop an optimized switch mode power amplifier (OSMPA) using existing techniques in sigma delta ($\Sigma\Delta$) architecture that will lead to the design of low cost, low power consumption transceivers with flexible frequency transmission. This design will allow all digital tunability and eliminate the need for cascaded analog components. The implementation will improve the output spectrum using the Cartesian $\Sigma\Delta$ structure by removing unwanted spectral components when the carrier frequency of the transmitted signal is changed. In addition, the new approach will improve the bandwidth and carrier frequency range by removing the noise and distortion products. Simulation results show that the new approach enables operation in the cellular frequency bandwidth with improved spectral efficiency.

Keywords— component; Optimised Switch Mode Power Amplifier (OSMPA); Sigma Delta Architecture; Low power; Spectral efficiency

I. INTRODUCTION

Existing network providers find it difficult to provide high data rates for indoor wireless coverage due to low spectral efficiency and uncontrollable channel conditions. As a result, this has motivated the recent emergence of Femtocell architectures [1-5]. According to [6], the mobile traffic generated in the indoor locations is expected to reach 81% (55% of all mobile traffic will occur at home and 26% will occur in the office). This percentage has been increasing over time and is expected to increase further. If a user has a home base station at his/her home (and office), then the existing macrocell networks need only carry the remaining 19% of traffic which is generated at outdoor locations. Femtocell networks rely on sharing frequencies with other similar networks [1][2] while enhancing the capacity and coverage indoors, consequently this activity may cause interference to other users in surrounding networks [3-5]. Therefore, Femtocell transceivers need to be low powered to

reduce their interference footprints. They should also have frequency flexibility to change channel quickly and avoid interference from other Femtocells. Next Generation Femtocell Base Stations (BS) will need to be small, low cost, power efficient, and frequency flexible if they are to meet the key challenges of achieving cost-efficient provision of coverage and capacity [7] [8]. This has led to renewed interest in transceiver architectures based on Pulse Width/Position Modulated signals (PWM/PPM) in Figure 1 where these signals can be generated from a polar representation of the transmitted signals. It is normal to quantise the phase and magnitude components of the modulation such that the pulse edges align with the digital clock (for synchronous digital design). Sigma Delta ($\Sigma\Delta$) modulation techniques applicable in Figure 2 can be used to suppress the quantisation noise but can generate unwanted spectral components when the carrier frequency of the transmitted signal is changed. Unacceptable noise and distortion occurs when the transmission is not centred on the nominal carrier frequency. Transmitters based on this technique are not qualified for frequency flexibility. The proposed work will therefore focus on methods to eliminate the noise and distortion products.

II. ANALYSIS OF EXISTING ARCHITECTURE

Existing 3G Base Stations require high efficiency linear radio RF-PAs. All nonlinear classes can be operated with a switching input waveform hence RF pulse width/position modulation (RF PWM/PPM) is an important technique in switched mode transmitter architectures. A novel all-digital approach to generate a pulse train to drive switch mode power amplifiers was proposed by [9]. In this work, it shows a better adjacent channel noise performance through the output with 1-bit drive signal from SMPAs. [10] Developed a system model to generate an appropriate binary signal in the pulse width and the pulse

position products to correct the amplitude and phase of the RF signal. [11] RF PWM/PPM enables the usage of highly efficient SMPA. Therefore, this concept makes RF PWM/PPM topologies feasible for GHz frequency band allowing usage for wireless application. $\Sigma\Delta$ Techniques shape the noise away from the band of interest where they operate by subtracting the current quantised error signal from subsequent samples [12]. This error feedback causes the $\Sigma\Delta$ system to act as a filter with separate transfer function for the noise and the signal. Higher $\Sigma\Delta$ orders have greater noise shaping capabilities. [13] and [14] simulated the 3rd order Lowpass $\Sigma\Delta$ scheme to improve the noise shaping for high frequency application. Noise in the band of interest is lower but out-of-band noise is larger. The latter must be removed by an analog output bandpass filter (Figure 1). In order to keep the BPF's insertion loss and complexity at a reasonable level, low $\Sigma\Delta$ orders (first/ second) are preferred Figure 2 and 3. There are three basic $\Sigma\Delta$ architectures that have been proposed in previous work namely Bandpass, Polar, and Cartesian.

III. COMPARATIVE DESIGN TECHNIQUE ANALYSIS

A bandpass filter (BPF) is used to remove the switching harmonics, leaving the required RF output (Figure 1). [15] Proposed a bandpass $\Sigma\Delta$ modulator used to produce a two-level (digital) signal representing an analog RF input. Subsequently, a switching-mode amplifier and bandpass filter are used to amplify the signal and remove unwanted spectral components. The BPF is used to remove unwanted spectral components from the output with a different approach that used the implementation of GaAs heterojunction bipolar transistor (HBT) technology.

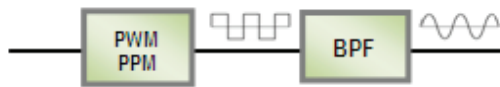

Figure 1. BPF for RF PWM/PPM output.

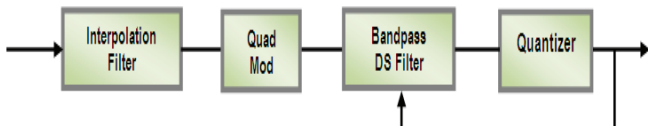

Figure 2. Bandpass $\Sigma\Delta$ Architecture [16].

This design allows the input baseband signal to be sample rate interpolated to a sampling frequency that is four times the required RF carrier frequency.

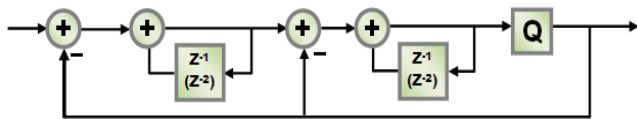

Figure 3. 2nd order low-pass $\Sigma\Delta$ (Bandpass uses Z^{-2} instead of Z^{-1}).

The quadrature modulation block upconverts the baseband signal to the RF carrier. The $\Sigma\Delta$ filter uses a bandpass structure, which is obtained by replacing Z^{-1} with Z^{-2} in traditional the low pass $\Sigma\Delta$ structures.

One problem is that the output signal can have more than one pulse per half period of the RF carrier. This can potentially increase switching losses. To solve this problem, the polar $\Sigma\Delta$ structure was proposed in [10, 17, and 18]. Authors in [10], [17], and [18] have studied the Polar $\Sigma\Delta$ structure in Figure 4. The $\Sigma\Delta$ filters for the phase signal must be modified to handle the phase wrap-around. The polar components have a wider bandwidth than the I-Q components, and this limits the modulation bandwidth of this structure.

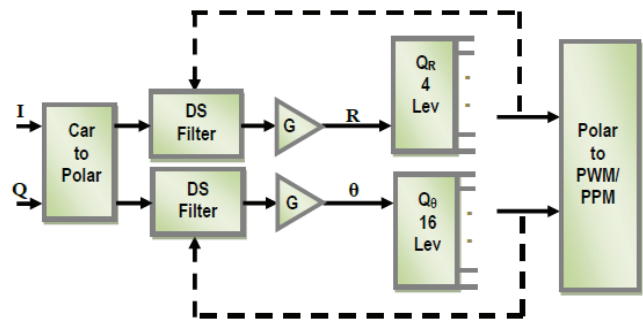

Figure 4. Polar $\Sigma\Delta$ Architecture.

Another problem is unwanted spectral components which arise when baseband polar signals are upconverted to RF using PWM/PPM techniques as in Figure 6. [17] Investigated that the dominant distortions are shown to be 3rd order harmonic and image components generated in the PPM circuit ('Polar to PWM/PPM' block). Cartesian filtering has been introduced in [18-20] to solve these problems.

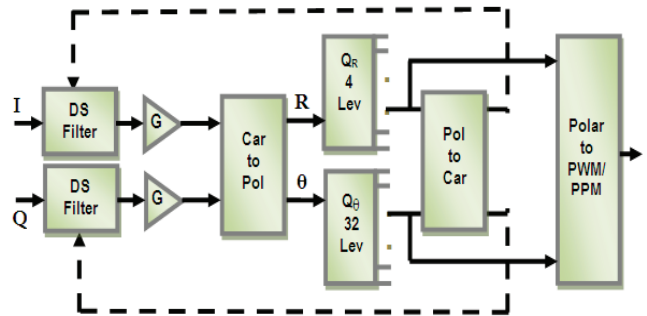

Figure 5. Cartesian $\Sigma\Delta$ Architecture.

The Cartesian $\Sigma\Delta$ structure [19] can be seen in Figure 5. It consists of second-order modulation (MOD2) lowpass $\Sigma\Delta$ [12] for the Cartesian I and Q input signals. After $\Sigma\Delta$ filtering I and Q signals are converted to polar co-ordinates [R, θ] and separately quantised in the Q_R and Q_θ blocks. The Gain block (normally set

to $G \leq 1$) works to improve efficiency (by reducing the number of switching edges) at the expense of a degraded spectrum [10]. The output of the quantisers are converted back to Cartesian coordinates (removing bandwidth expansion) and fed as feedback to the $\Sigma\Delta$ filters. The outputs of both quantisers are also upconverted to RF using PWM/PPM techniques in the ‘polar to PWM/PPM’ block.

While reducing the bandwidth expansion, the Cartesian $\Sigma\Delta$ may still cause unwanted spectral components (Figure 5 and 6). [20] Established that in a single carrier environment, an increase in offset frequency increases the unwanted spectral components. The 3rd order harmonic and image components are the dominant distortions as shown in Figure 6. The PPM block is responsible for these distortions.

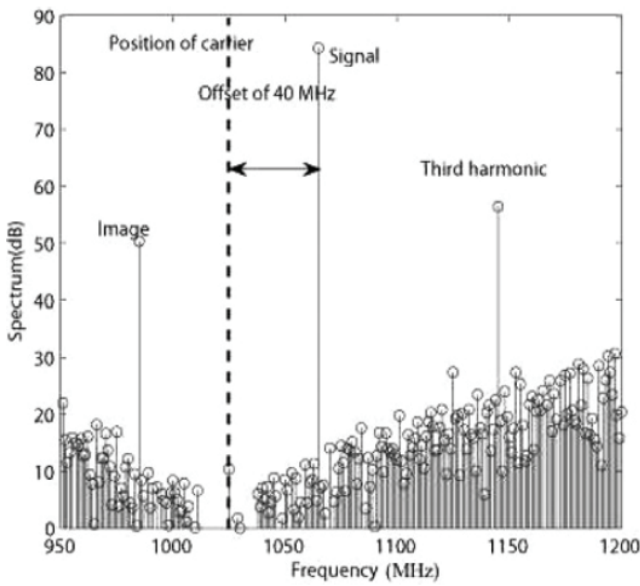

Figure 6: SSB output spectrum from a Cartesian $\Sigma\Delta$ where the distortions are from the PWM/PPM. The image and harmonic products are also shown ($f_c=1024$ MHz and $f_{ssb}=40$ MHz) [20].

IV. DESIGN PROPOSAL OF OSMPA WITH DPD CASCADE AND ACHIEVED RESULTS

Based on previous work by [20], one possible solution is to introduce digital pre-distortion based on the rate of phase change of the input signal as in Figure 7. This approach is to try and eliminate noise and distortion products.

This structure will allow all digital tunability and eliminate the need for analog components. The design improves the output spectrum of switched mode RF-PAs using the Cartesian technique. This involves removing unwanted spectral components when the carrier frequency of the transmitted signal is changed. To improve the bandwidth and carrier frequency range by removing the noise and distortion products.

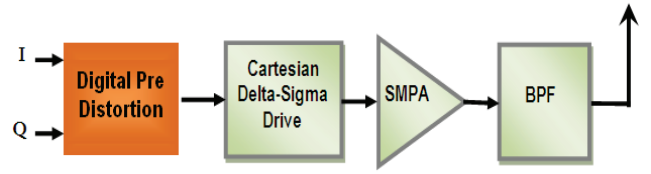

Figure 7. Proposed system design.

This will enable operation in the cellular frequency bandwidth, increasing the applicability of the scheme and will improve spectral efficiency. To demonstrate the scheme viability, a prototype is implemented in digital hardware using a field-programmable gate array (FPGA). The quantization noise in the signal spectra is shaped by the $\Sigma\Delta$ noise transfer function (NTF) where the noise power spectral density (PSD) increases as the frequency deviates from the nominal centre frequency. Pre-emphasis of the input signal can be used to boost signals that are offset from the nominal carrier frequency (Figure 8 and Figure 9). This will then compensate the increased noise and distortion products in this region. Such a scheme is commonly used for frequency modulation (FM) transmission, but the accuracy of this technique in this application is yet to be tested.

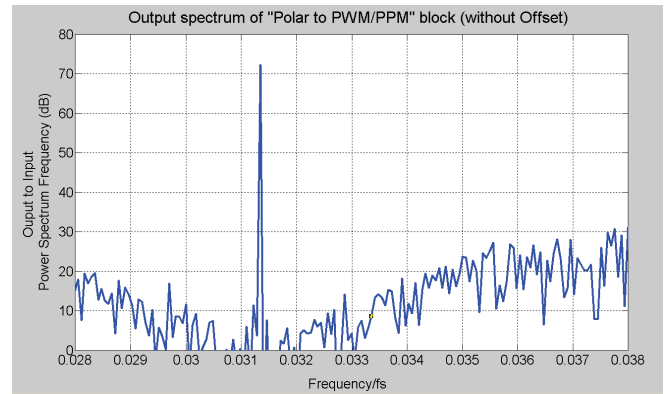

Figure 8. Output of Polar to PWM/PPM block without offset

V. CONCLUSION

So far simulation results have shown that the approach we have taken will lead to determining where the image and harmonic products are located in the given bandwidth and hence eliminate them using the architecture depicted in Figure 7. The quantization noise in the signal spectra is shaped by the $\Sigma\Delta$ noise transfer function (NTF). The noise power spectral density (NPSD) increases as the frequency deviates from the nominal centre frequency. Pre-emphasis of the input signal can be used to boost signals that are offset from the nominal carrier frequency. This will then compensate the increased noise and distortion products in this region. More work will need to be done to fully optimise the proposed architecture.

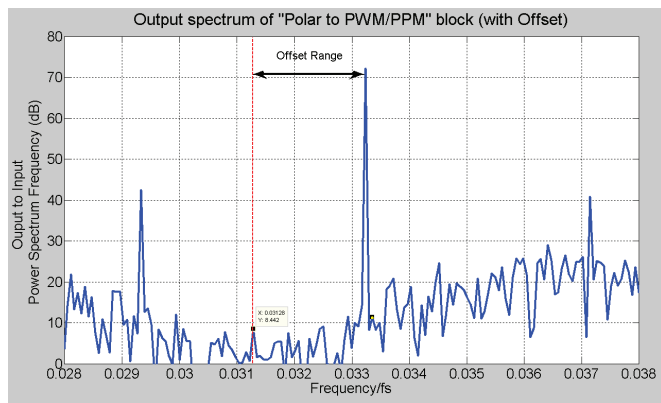

Figure 9. Output of Polar to PWM/PPM block without offset

REFERENCES

- [1] W. Yi, Z. et al. "A Novel Spectrum Arrangement Scheme For Femtocell Deployment In LTE Macrocells" in Proc. IEEE 20th Int. Symp PIMRC Japan, 13-16 September 2009.
- [2] P. Pirinen, "Co-Channel Co-Existence Study Macrocell and Indoor Femtocell Users" in Proc. European Wireless Conference (EW'10) Italy, pp. 207–213. April 2010.
- [3] D. Lopez-Perez, et al, "OFDMA Femtocells: A Roadmap on Interference Avoidance", IEEE Communications Magazine, Vol. 47, Issue 9, pp. 41–48, September 2009.
- [4] Y. Tokgoz, et al, "Uplink Interference Management for HSPA+ and Ixevdo Femtocells" in Proc. IEEE, GLOBECOM, Honolulu, December 2009.
- [5] S. Zhenning, R. Mark C., and Z. Ming, "On Uplink Interference Scenarios in Two-Tier Macro and Femto Co-Existing UMTS Networks", EURASIP journal on Wireless Comm. & Networking, Volume 2010.
- [6] www.femtoforum.org. "Mobile Broadband Access at Home-ITM, August 2008" in Femtocells-Natural Solution for Offload June 2010 (access 16 Mar 2011).
- [7] Ericsson white paper, <http://www.ericsson.com/res/docs/whitepapers/wp-50-billions.pdf> (access 10 March 2011).
- [8] V. Sunil, "Trends in Green Wireless Access" Fujitsu Sci.Tec., Vol.45, October 2009.
- [9] V. Bassoo and M. Faulkner, "Sigma Delta Digital Drive Signals for Switch mode Power Amplifiers", Electronic Letters, Vol. 44, Issue 22, pp. 1299-1300, October 2008.
- [10] H. Sjoland, et al, "Switched Mode Transmitter Architectures," in Analog Circuit Design Smart Data Converters, Filters on Chip, Multimode Transmitters, A.H.M Van Roermund, Ed. Netherlands: Springer, pp. 325-342, 2009.
- [11] B. T. Thiel, et al, "System Architecture of an All-Digital GHz Transmitter using Pulse-Width/Position-Modulation for Switching Mode PAs," Asia Pacific Microwave Conference (APMC), pp.2340–2343, December 2009.
- [12] R. Schreier and G.C. Temes, "Understanding delta-sigma data converters" Wiley Press, 2004.
- [13] D. Gautier, et al., "Improved Delta Sigma Modulators for high speed applications", in Circuits and Systems IEEE International Midwest Symposium, pp. 385-388, Augustus 2009.
- [14] M. Helaoui, et al., "A Novel Architecture of Delta-Sigma Modulator Enabling All-Digital Multiband multistandard RF Transmitters Design", [Circuits and Systems IEEE Transactions](http://www.ieee.org). Vol. 55, issue 11, pp. 1129-1133, November 2008.
- [15] A. Jayaraman, et al, "Linear High-Efficiency Microwave Power Amplifier Using Bandpass Delta-Sigma Modulators", IEEE Microwave and Guided Wave Letters. Vol. 8, No.3, 1998.
- [16] J. Keyzer, et al, "Generation of RF Pulse width modulated microwave signals using Band-pass Delta Sigma Modulation", Tech. Dig, MTT-2, 2001.
- [17] V. Bassoo, A. Mustafa, M. Faulkner, 'Distortion arising from polar to PWM/PPM conversion in an all digital up converter for switching RF power amplifier'. In Proc. IEEE IMS Int. Microwave Symp., Boston, USA, pp. 1533–1536. June 2009.
- [18] V.K. Parikh, et al., "All Digital-Quadrature-Modulator Based Wideband Wireless Transmitters", IEEE Transactions on Circ. & Syst., Vol. 56, pp. 2487-2497, November 2009.
- [19] V. Bassoo et al, "A potential transmitter architecture for future generation green wireless base station", EURASIP Journal on Wireless Com. & Net. Vol. 2009, Article ID 821846.
- [20] V. Bassoo, Linton L., Faulkner M., 'Analysis of distortion in pulse modulation converters for switching radio frequency power amplifiers' IET Microwave. Antennas Propag. Vol. 4, Issue. 12, pp. 2088-2096, December 2010.