

PNEUMATIC ACTUATOR AS VERTICAL DYNAMIC LOAD SIMULATOR ON THE SUSPENSION MECHANISM OF A QUARTER VEHICLE WHEELS

By Simon Kaka



2
PNEUMATIC ACTUATOR AS VERTICAL DYNAMIC LOAD
SIMULATOR ON THE SUSPENSION MECHANISM OF
A QUARTER VEHICLE WHEELS

Sinon Kaska^{1,2}, Syukri Himran², Ilyas Renreng² and Onny Sutresman²

¹Department of Mechanical Engineering, State Polytechnic of Ujung Pandang, South Sulawesi, Indonesia

²Department of Mechanical Engineering, Engineering Faculty, Hasanuddin University, South Sulawesi, Indonesia

E-Mail: kakasimon@gmail.com

ABSTRACT

Most of all road damage can be caused by dynamic loads of vehicles that fluctuate according to the type of vehicle that passes. This study aims to calculate the vertical dynamic load of the vehicle actually which occurs on road construction after through the vehicle wheel suspension mechanism. The Pneumatic cylinder that was driven by pressurized air directly weighs on the Spring and Shock Absorber that contained on the wheels of the vehicle. The load fluctuations of the medium weight category vehicle are determined by the regulation of the amount of pressurized air entering into the pneumatic cylinder chamber pushing the piston and connecting rods. The deviation that occurs during compression on the spring and Shock Absorber is substituted into the vehicle dynamic load equation by taking also the magnitude of the spring stiffness constant, and the fluid or gas coefficient of the damper. The results showed that the magnitude of the displacement when the compression force worked has significantly influenced the amount of vertical dynamic load of the vehicle that overlies the road construction. Experimental results using pneumatic actuators instead of real dynamic vehicle loads illustrate the characteristics of the relationship between work pressure and dynamic load. If the working pressure of P_2 (bar) is given great, the vertical dynamic load F_t (N) which overloads the structure of the road is also greater. From the graph shows that shock absorbers have greater ability to reduce dynamic load vertically when compared to spring ability.

Keywords: dynamic load, pneumatic cylinder, pressurized air, suspension, road.

1. INTRODUCTION

A number of four-wheel vehicles passing over the surface of the highway at any time result in a number of dynamic loads that fluctuate. Besides this fluctuating loading sourced from the dynamic load variation, VBD can also be caused by overload, OL and repetition loads (RL) [1].

The effects of fluctuating load (FL) transfer, Overloads, and Repetition Loads will decrease the capability or stability of the road structure in the form of hollow or bumpy surface deformations. The ability of the road structure to receive the vehicle's vertical dynamic load is dependent on the type of surface layer, the elastic foundation layer, and the sliding foundation layer.

The variations of vehicle weight categories light, medium and heavy that pass over the road surface simultaneously will greatly affect the ability of the elastic foundation road layer to receive the load. Based on these problems, it is necessary to study the variables that influence either directly or indirectly against the roads surface structure. This fluctuating load can also be affected by the variable weight of the axle and the body of the vehicle.

The recurrent of loading conditions are also strongly influenced by the traffic loop currents, the average traffic volume (Number of vehicles/hour) which generated by each vehicle type and the duration of the vehicle passing.

An effort which is conducted to assess the dynamic load of a medium-weighted vehicle passing through the road that required an experiment on the

loading of a quarter of a vehicle centered on a front wheel of a vehicle. This inspiration is based on a basic knowledge of the mechanism of vertical load transfer through a wheel suspension system consisting of spring work and shock absorber.

A study of dynamic loads transformed through the mechanism of suspension work on the wheels of vehicles on the road is aimed at knowing the shape of the formula and the magnitude of the vertical dynamic load of all types of medium weight vehicles passing by, Knowing the path capability characteristics that are receiving repetition loads and Overloads, and produces a relationship or comparison between the vehicle's vertical dynamic load and the path capability in the form of a dimensionless parameter.

A novelty targeted in this study is to utilize pneumatic actuators on test equipment or experiments as a replacement for real dynamic loads of vehicles overloading the road structure.

The pressurized air from the compressor provides compression forces varying extensively to the spring and shock absorber contained in the suspension system.

The mechanism of passive suspension work and the condition of a quarter vehicle loading structure is shown in Figure-1 [2, 3]. The weight of the vehicle (mass sprung) m_2 with the rigidity of the spring k_2 and the damping coefficient c will overload the vehicle's wheel axle (mass un-sprung) m_1 further gives the action force to the contours of the road surface.



For the category of lightweight vehicle has an axis load of $m_1 = 400$ kg, and vehicle weight, $m_2 = 835$ to 1394 kg, the medium weight category vehicle has axis load, $m_1 = 480$ to 600 kg and vehicle weight, $m_2 = 1185$ to 1990 kg, while the heavy category vehicle has axis load, $m_1 = 525$ to 850 kg, and vehicle weight, $m_2 = 5200$ to 8730 kg (source: P.T. Astra International, 2014, Appendix 1). The overloading conditions OL is depending on the constant value, k and the axis load m_1 (kg) for each vehicle type.

The constant value of $k = 1$ for a single axis; $k = 0.086$ for double axis and $k = 0.031$ for triple axis.

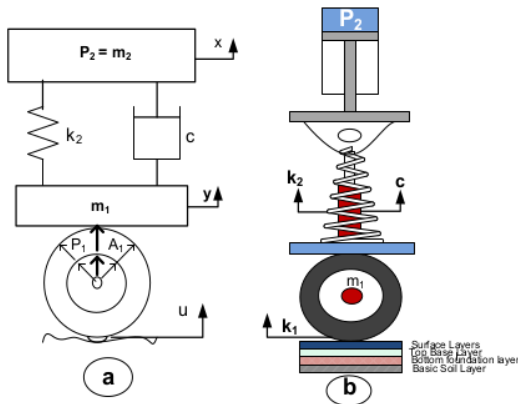

Figure-1. (a) Passive suspension model (b) Suspension unit, shock absorber, spring and wheel of vehicle on road layer structure.

The reaction force of the road contour to the tire will be distributed in the direction of u through the tire elasticity constant of k_1 . The magnitude of the vertical dynamic force by the equivalent pneumatic actuator in the weight of the vehicle body (2) is described in (2.5). Compression drifts as far as x_2 (cm) will vary according to the magnitude of the working pressure of P_2 (bar) which varied from 1 to 8 bar, the addition of 1 bar.

$$\begin{aligned}
 F_{p2} = F_{ef} = F_k - R_f = F_k - 0.1F_k = 0.9F_k \\
 \sum F_v = 0 \\
 F_{ef} - (F_{k2} + F_{c2}) = 0 \\
 0.9 F_k - (k_2 + c)x_2 = 0 \\
 F_k = \frac{(k_2 + c)x_2}{0.9} \\
 F_{p2} = F_k = 1.1(k_2 + c)x_2
 \end{aligned} \quad (1)$$

If the force F_{p2} works collaboration with the axis force on the wheel (1) then the relationship is obtained:

$$\left. \begin{aligned}
 F_{t1} = F_{p2} + F_{r1} \\
 F_{t1} = 0.9F_k + (m_1 \cdot g)
 \end{aligned} \right\} \text{(N)} \quad (2)$$

If the diameter of piston, $D = 100$ mm (0.100 m), k is spring constant, c is damping coefficient, m_1 is axle weight, gravity acceleration $g = 10$ m / s² and pneumatic cylinder thrust force, $F_k = \pi / 4 D^2 P_2$, then equation (2) becomes:

$$F_{t1} = 785 P_2 + 10m_1 \text{ (N)} \quad (3)$$

The effective force F_{ef} (N) of piston cylinder in the step forward is the difference between the theoretical forces, F_k (N) and friction force R_f (N) [4, 5]. If the friction force R_f is set to 10 % $x F_k$ (N) the overall load transfer mechanism on the asphalt road structure is referring to the following Free Body Diagram (FDB):

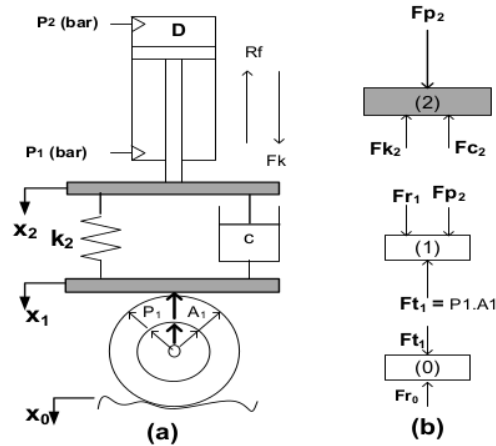

Figure-2. (a) Mechanism of loading process with experimental pneumatic systems, (b) Free body diagram of the forces.

If the springs and the shock absorber are subjected to varying loads of the pressure, P from 1 to 8 bar, there will be a deviation toward the compression as far as x (mm). Under the action-reaction law, it is explained that the load applied to the spring is proportional to the magnitude of the deflection multiplied by the spring constant.

The magnitude of the average displacement in the optimized suspension system $x = 0.009264$ m with maximum vertical acceleration is 9.5707 m / s².

In this condition, the coefficient of stiffness coefficient of the suspension spring $k_s = 41821$ N / m, and the suspension damper coefficient $c_s = 68574$ N.s / m and $c_s = 1920$ J / kg.K [6, 7].

The suspension prototype tested by [8] has spring constant data $k_s = 10581.292$ N / m, shock damping coefficient, $c_s = 96,073$ Ns / m and tire elastic constants, to $= 98041,246$ N / m. A study of the relationship between piston diameter D and hole diameter d_i in the preliminary study [4] in the form of equation (4).



$$d_i = 0.065713 D \quad (4)$$

The dimension of the air distribution channel that will be used is adjusted to the dimensions of the selected pneumatic cylinder piston. Based on the specifications of tires and wheels, that for light and medium weight vehicles used standard air pressure in tires of 2 bar, and 5.86 bar for heavy vehicles.

If the size of tires and wheels are used dimensions less: $215/60/16$ which it means, the width of the tire, $S=215$ mm, high $T=60\% \times S$ (mm) = 129 mm = 0.129 m, and wheel diameter, $D_1=16$ "(inches) = 16×25 mm = 400 mm = 0.4 m, air pressure in the tires, $P_1=2$ bar = 200000 N/m², and tire area $A_1 = \pi[r_o^2 - r_i^2] = 3.14[0.102^2 - 0.020^2] = 0.031412$ m², Then the inner force of the tire and the wheel holding the vehicle's vertical load is $F_{t1} = P_1 \times A_1 = 6282.4$ N.

The magnitude of the vehicle dynamic load coefficient is formulated [9] as a comparison between the average dynamic load and the static load as follows:

$$DLC = \frac{\text{Average of dynamic loads}}{\text{Static load}} = \frac{F_{Drms}}{F_s} \quad (5)$$

For vehicles with hydro-pneumatic suspension, the dynamic load can be reduced by 20%. [10] Under these conditions, The Dynamic Load Coefficient (DLC) formulated as, $DLC = \frac{(100-20)\%}{100\%} = 0.80$. When the $\frac{1}{4}$ vehicle wheel is rolling over the road surface, the vehicle's vertical dynamic load is formulated as follows:

$$\left. \begin{aligned} F_{DV} &= 0.8 \times F_{t1} \\ &= 628P_2 + 8m_1 \leq F_{A0} \end{aligned} \right\} (N) \quad (6)$$

2. RESEARCH METHODS

Experimentally, the loading of the road foundation structure was performed by equaling the total vehicle weight of m_1 and m_2 with the pneumatic cylinder thrust force, F_{ef} . (N). The magnitude of the thrust is varied according to the working pressure setting, $P_2 = 1$ to 8 (bar).

This research is oriented on the simulation of pneumatic cylinder piston thrust as a replacement for real dynamic vehicle load as shown in Figure-3(a).

If the compressive force of the pneumatic cylinder piston thrust the spring and the shock absorbers, there will be a compression process indicated by the designation of the needle x at the displacement scale (mm).

Based on the loading simulation, the experimental data collection is done by reading the scale (11) of needle designation or dial displacement indicator, x (mm) at the time of occurring compression on the spring (10).

Control of pneumatic cylinder piston motion which overloads the suspension system on the wheels, is carried out by the method of electrically conducting, 24 Volt DC at the control valve 5/2 solenoid single actuation.

The magnitude of the change in displacement is determined by the amount of air pressure P_2 (bar) which arranged from 1 (bar) to 8 (bar).

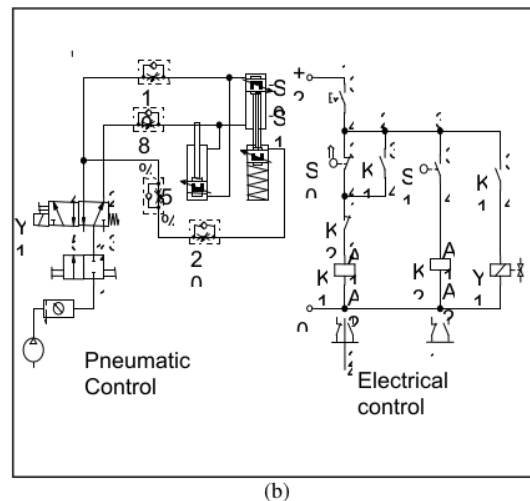
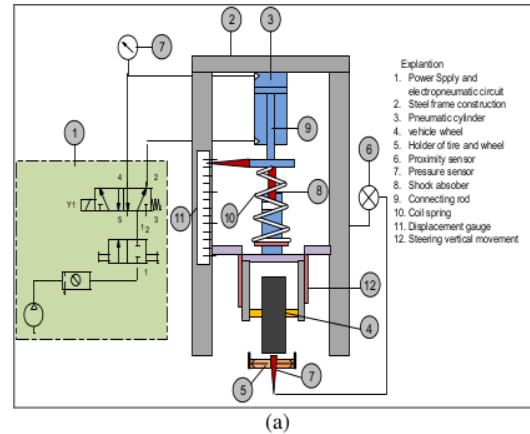

Figure-3. (a) Simulation of wheel suspension loading with pneumatic actuators (b) Control of electro-pneumatic system.

In order for the measurement of the deviation, x (mm) can be closed to the real state, at every working pressure setting condition, it is necessary to measure the deviation, x (mm) 5 times. The real state can be obtained by calculating the average value of x (mm).

The magnitude of the average displacement, x (mm) which has been obtained, can substituted further into the equation (2) and (3) to derive the weight of the vehicle, Fp_2 (N) and the vehicle's real vertical dynamic force, Ft_1 (N) against the road construction. With the help of Mat-Lab / Simulink program analysis, then the magnitude Fp_2 (N) and, Ft_1 (N) can be obtained, as well as the loading characteristics performed on the road construction can be shown through graphic drawings.



3. RESULTS AND DISCUSSIONS

The dynamic load simulation of vehicles which acted by the pneumatic cylinders as actuator, can result in the magnitude of the dynamic load of vehicles that overload the road structure is referring to equation (4).

If the working pressure, P_2 which acts as a load of m_2 is varied from 1 bar to 8 bar, the characteristics of the pressurized air pressure working against the vertical dynamic load are shown in Figure-4.

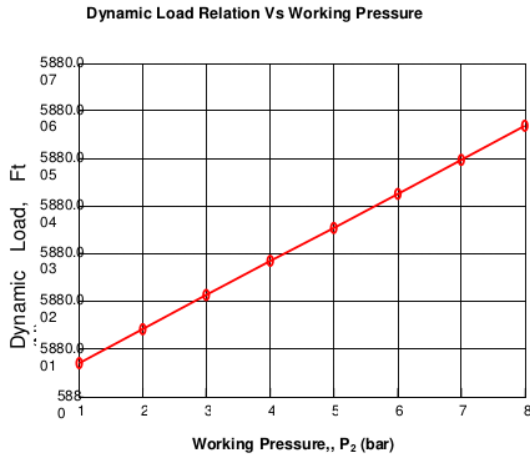

Figure-4. Dynamic load characteristics of pneumatic systems.

The dynamic load characteristics which obtained from the relation between the working pressure and the spring constant, k_2 , the pneumatic cylinder piston force, F_{P2} , the absorbing shock absorber, c_2 and the magnitude of the vertical dynamic load that weighs the F_{I1} road structure are shown in Figure-5 (a).

The damping of the shock absorber gives a huge influence on the dynamic load of the vehicle overloading the road structure. Such a condition causes the dynamic load of F_{I1} (N) according to Figure-5 (b) to be around 10000 (N) or equivalent to 1000 kg.

So if the vehicle of the weight category being tested has the weight of wheel axis, $m_1 = 600$ kg, body weight, $m_2 = 1665$ kg and total weight / net, $m_t = 2265$ kg according to the data in Table 4.1, then the reduced dynamic vehicle load is $m_r = m_t - 1000$ kg = $2265 - 1000 = 1265$ kg.

The dynamic load drop presentation that weighs the structure of the path by the attenuation of the shock absorber is $\frac{2265}{1265} \times 100\% = 55.85\%$.

Figure-1.6 (a) shows an adequate fantastic picture that the attenuation of the shock absorber attached to the vehicle suspension mechanism gives a damping value, c (Ns/cm) to a very large dynamic load, ranging from 4523.729 Ns/cm and 48702.041 Ns/cm.

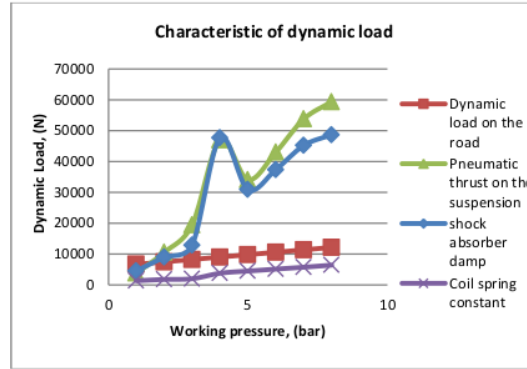

(a)

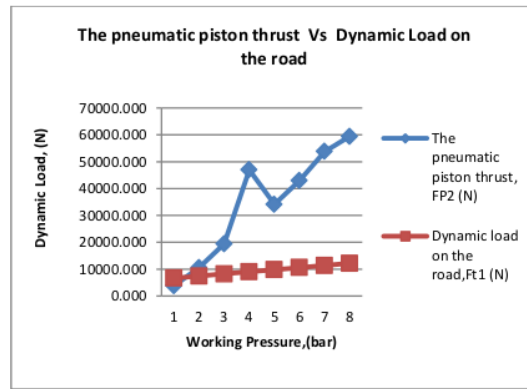

(b)

Figure-5. (a) Characteristics of the dynamic load by piston force, F_{P2} against spring and shock absorber. (b) The relationship between the F_{P2} piston force and the dynamic load F_{I1} which overloads the road structure.

The smallest effect of attenuation that is also used in vehicle suspension system is the contribution of coil spring-attenuation, k_2 (N / cm) whose value is between 1330.508 N / cm and 6408.163 N / cm.

The gap value that occurs between the absorbers of the shock absorber and the coil spring indicates that the shock absorber has a very large function to reduce the vibration caused by the vehicle's vertical dynamic F_{I1} .

Figure-6 (b) describes the relationship characteristics between the dynamic load of the experimental results and the actual dynamic load that occurs.

By using a 20% Dynamic Load Coefficient value which applicable to the vehicles with hydro-pneumatic suspension, the actual vertical vehicle dynamic load transformation according to equation (2.10) has a value of between 5332 (N) and 9728 (N) or less than the Weighted value of 10000 (N).

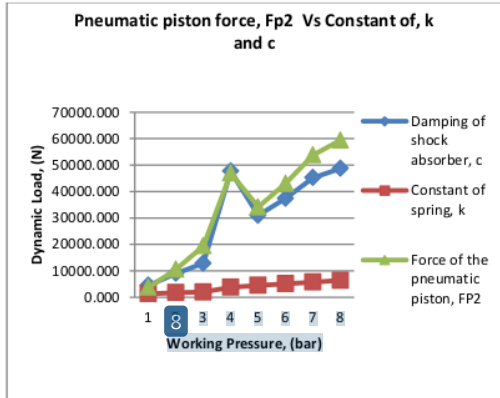

(a)

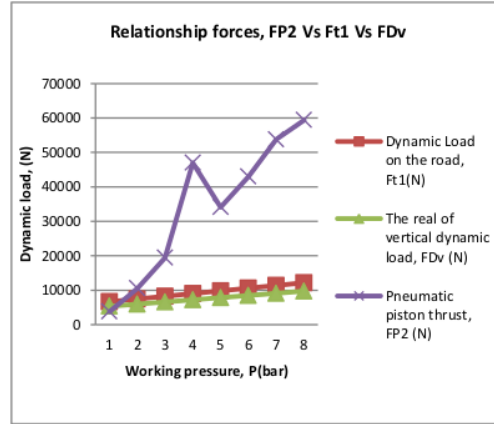

(b)

Figure-6. (a) The relationship between the piston force F_{P2} (N) and the shock absorber and the coil spring, (b) The relationship between the piston force, F_{P2} (N) of the pneumatic cylinder and the dynamic load, F_t (N) of the test vehicle and the dynamic load real vertical, F_{Dv} (N).

It can also present the results of dynamic load analysis using equations (2.2), (2.4) and equations (2.7).

A number of important data obtained from several formulas for experimental test vehicles are shown in Table-1.

Table-1. Results of dynamic vertical load analysis for medium weight vehicles.

Working pressure P_2 (bar)	Weight axle $W_1=m_1.g$	Dynamic load on the road $F_{t1}=F_{r0}$ (N)	Real vertical dynamic load F_{Dv} (N)	Pneumatic cylinder thrust force F_{P2} (N)
1	5880	6665	5332	3799.400
2	5880	7450	5960	10534.700
3	5880	8235	6588	19428.750
4	5880	9020	7216	46974.400
5	5880	9805	7844	34108.250
6	5880	10590	8472	43002.300
7	5880	11375	9100	53796.050
8	5880	12160	9728	59408.800

The magnitude of the vertical dynamic load, F_{Dv} (N) as contained in Table-1 can be identified as the normal force, F_N (N) acting in a direction perpendicular to the horizontal force, F_H (N) and the tangential force, F_T (N).

4. CONCLUSIONS

a) Characteristics of the suspension mechanism on the wheels of a quarter vehicle for medium-weight vehicle type, experienced the largest deviation 0.98 cm with a vibration time of 1.5 seconds. Within 30 seconds later, the vibrations begin to shrink and disappear in the last 10 seconds.

b) Medium weight category vehicle with total weight: 2265 kg > 1942.8 kg, obtained real vertical dynamic load greater than 658.8 kg. The percentage decrease of dynamic load of vehicles that overload the structure of the road by the absorption of the shock absorber is 55.85%.

3 ACKNOWLEDGEMENT

The authors would like to thank to the Department of Mechanical Engineering Hasanuddin University and also to the Department of Mechanical Engineering, State Polytechnic of Ujung Pandang for providing the facilities in Workshop and Laboratory.



REFERENCES

- [1] Manjunatha T. R1, Byre Gowda, Dr. H. V2 Prabhunandan. G. S3. 2013. Design and Static Structural Analysis of Cylinder and Piston of Two Stage Reciprocating Compressors Using ANSYS. International Journal of Innovative Research in Science, Engineering and Technology (An ISO 3297: 2007 Certified Organization). 2: 7.
- [2] A. Rehnberg. 2008. Vehicle dynamic analysis of wheel loaders with suspended axles. TRITA-AVE. Vol. 15.
- [3] K.Ogata. 1997. Modern Control Engineering (3 ed.).
- [4] M.M. Simon Ka'ka. 2013. A method to compute the Dimension of An Air Distribution Channel of A Pneumatic Cylinder. Presented at the IGCESH Conference, Johor Bahru, Malaysia.
- [5] O.S.a.S.T. A. Ilchmann. 2006. Pneumatic cylinders: modelling and feedback force-control. International Journal of Control. Vol. 79.
- [6] b. Yuxin Zhang a. 2016. Konghui Guo a, Dai Wang c, Chao Chend. Energy conversion mechanism and regenerative potential of vehicle suspensions. Energy Conversion and Management. pp. 1-10.
- [7] M. Tongyi XuaChuan Lib, Shuai Yanga. 2015. Design and analysis of a shock absorber with variable moment of inertia for passive vehicle suspensions. Journal of Sound and Vibration, vol. 355, p. 20, 2015.
- [8] C. S. Shrikant S Dodamani#1, Nagaraj D#3. 2016. Design and Fatigue Analysis of McPherson Strut Assembly Coil Spring. International Journal of Innovative Research in Science, Engineering and Technology. 5: 11.
- [9] Caitrans. 2005. Simulation of a Mobile Crane's Dynamic Load Using the CraneSim Program. The Pavement Research Group. 1(1): 2.
- [10] P.A. Tospol Pinkaew. 2007. Experimental study on the identification of dynamic axle loads of moving vehicles from the bending moments of bridges. Engineering Structures. Vol. 29.

PNEUMATIC ACTUATOR AS VERTICAL DYNAMIC LOAD SIMULATOR ON THE SUSPENSION MECHANISM OF A QUARTER VEHICLE WHEELS

ORIGINALITY REPORT

11%

SIMILARITY INDEX

PRIMARY SOURCES

- | | | |
|---|---|-----------------|
| 1 | repository.petra.ac.id
Internet | 162 words — 5% |
| 2 | www.semanticscholar.org
Internet | 52 words — 2% |
| 3 | S Ka'ka, R Tandioga, Lewi, A K Muhammad, A Rahman, A Taufik. "The Development Mechanism of Microcontroller-Based Water Level and Temperature Control", IOP Conference Series: Materials Science and Engineering, 2019
Crossref | 32 words — 1% |
| 4 | pasca-umi.ac.id
Internet | 22 words — 1% |
| 5 | eprints.hud.ac.uk
Internet | 18 words — 1% |
| 6 | D Dermawan, H Abbas, R Syam, Z Djafar, A K Muhammad. "Finite element analysis on vibration of a flexible single-link manipulator moved translationally", IOP Conference Series: Materials Science and Engineering, 2019
Crossref | 15 words — < 1% |
| 7 | ut.linuxpowered.net
Internet | 14 words — < 1% |

-
- 8 docslide.us
Internet 10 words — < 1%
-
- 9 Xiaomin Dong, Jun Xi, Pinggen Chen, Wenfeng Li.
"Magneto-rheological variable inertia flywheel",
Smart Materials and Structures, 2018
Crossref 9 words — < 1%
-
- 10 "Recent Advances in Sustainable Technologies",
Springer Science and Business Media LLC, 2021
Crossref 8 words — < 1%
-
- 11 Shiwu Li, Xueping Yao, Zhifa Yang, Lihong Wang,
Wencai Sun. "Monitoring Technology for Vehicle
Loading Status Based on the Analysis of Suspension Vibration
Characters", Advances in Mechanical Engineering, 2015
Crossref 8 words — < 1%
-
- 12 Deng, Lu. "System Identification of Bridge and
Vehicle Based on their Coupled Vibration",
Louisiana State University and Agricultural & Mechanical
College, 2022
ProQuest 6 words — < 1%

EXCLUDE QUOTES OFF

EXCLUDE BIBLIOGRAPHY ON

EXCLUDE SOURCES OFF

EXCLUDE MATCHES OFF